

### IMPORTANT:

Programming should be done by a qualified installer who is trained on programming inverter power systems. Failure to program accurate parameters for the system could potentially cause equipment damage. Damage caused by inaccurate programming is not covered by the limited warranty for the system.

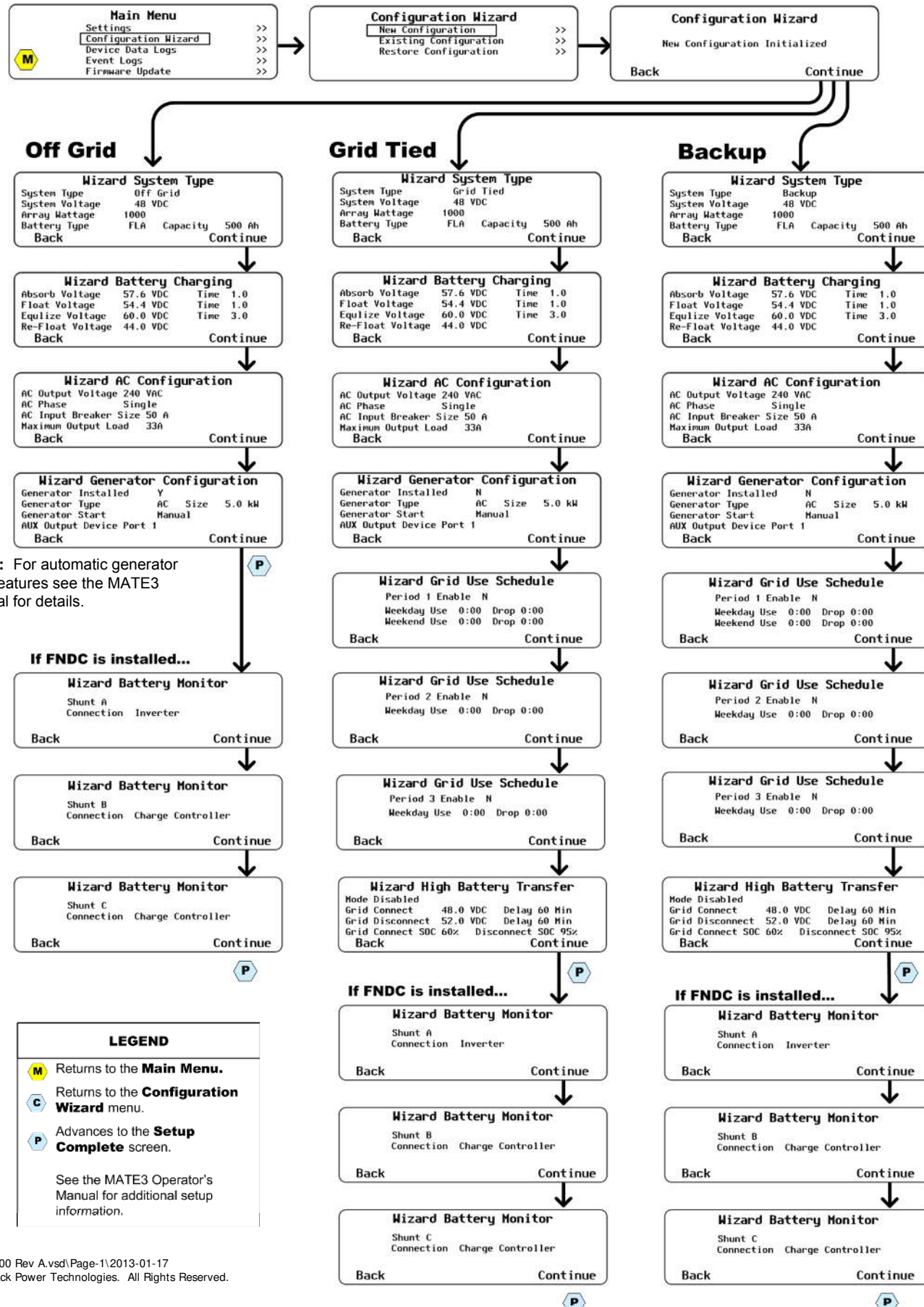

Note: For automatic generator start features see the MATE3 manual for details.

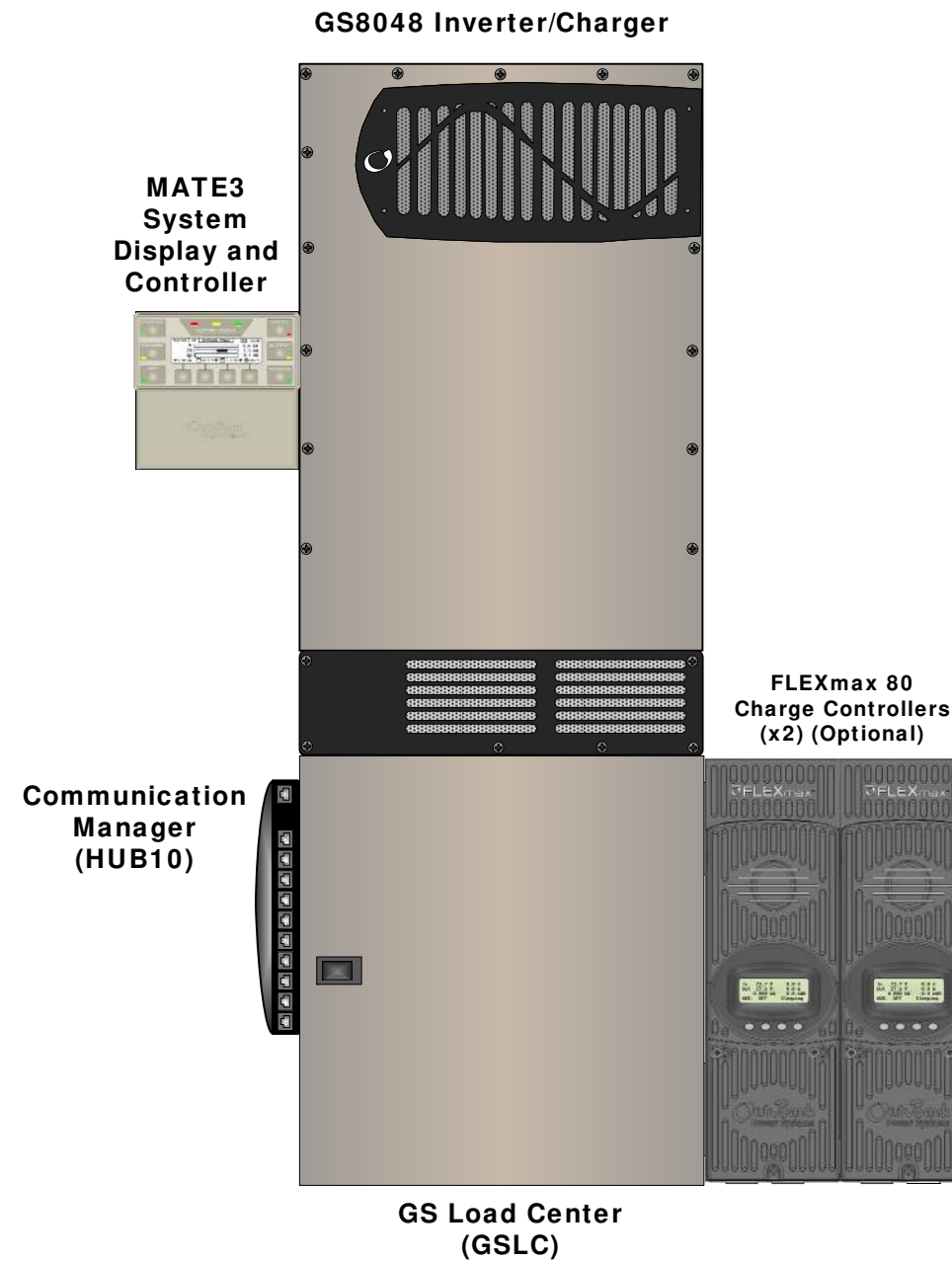

Major Components	
Radian System Products	
Inverter/Charger	GS8048
GS Load Center	GSLC175-PV-120/240
System Display and Controller	MATE3 (FW-MB3 mounting bracket)
Communications Manager	HUB10 HUB 4
FLEXnet DC Monitor (FNDC) Surge Protector Remote Temperature Sensor (RTS)	

Optional OutBack Components	
Charge Controller	FLEXmax 80* FLEXmax 60*
*Including appropriate Mounting Bracket.	
PV Combiner Box	PV8 PV12

Customer-Supplied Components	
AC Source	Utility Grid, or AC Generator
Main Electrical Panel (or overcurrent device for the AC source)	
Electrical Distribution Subpanel (Load Panel)	
Battery Bank	
Photovoltaic (PV) Array (with PV Combiner Box [PV8 or PV12])	

FNDC LED Indicators	
Color	Battery State-of-Charge
Green	> 90% (blinks if charge parameters are met)
Yellow	≥ 80%
Yellow	≥ 70%
Yellow	≥ 60%
Red	≥ 60% off, < 60% solid, < 50% blinks

**IMPORTANT:**  
Not intended for use with life support equipment.



**Contact Technical Support:**  
Telephone: +1.360.618.4363  
Email: Support@outbackpower.com  
Website: www.outbackpower.com





### WARNING: Fire/Explosion Hazard

Do not place combustible or flammable materials within 12 feet (3.7 m) of the equipment. This unit employs mechanical relays and is not ignition-protected. Fumes or spills from flammable materials could be ignited by sparks.



### WARNING: Personal Injury

Use safe lifting techniques and standard safety equipment when working with this equipment.



### IMPORTANT:

Clearance and access requirements may vary by location. Maintaining a 36" (91.4 cm) clear space in front of the system for access is recommended. Consult local electric code to confirm clearance and access requirements for the specific location.

### Radian Dimensions (includes MATE3 and 2 FLEXmax 80 Charge Controllers):

29.1" (85 cm) tall X 35.4" (50 cm) wide

### Radian Mounting:

- Ensure the mounting surface is strong enough to handle 3 times the total weight of all the components. Add a piece of plywood if necessary to strengthen the surface.
- Attach the wall bracket to the surface centering the mounting holes on the sides with the wall studs. Use all 6 mounting screws to secure the bracket.
- Lift the inverter so that the inverter bracket is above the wall bracket.
- Lower the Inverter into place so that the inverter bracket slips into the wall bracket.
- Secure the inverter to the surface using a minimum of 1 wall screw (or other appropriate hardware).
- Follow the instructions for installing the GS Load Center.
- Follow the instructions for installing the HUB Communication Manager.
- Follow the instructions for installing the brackets for the charge controllers.
- Follow the instructions for installing the bracket for the MATE3.

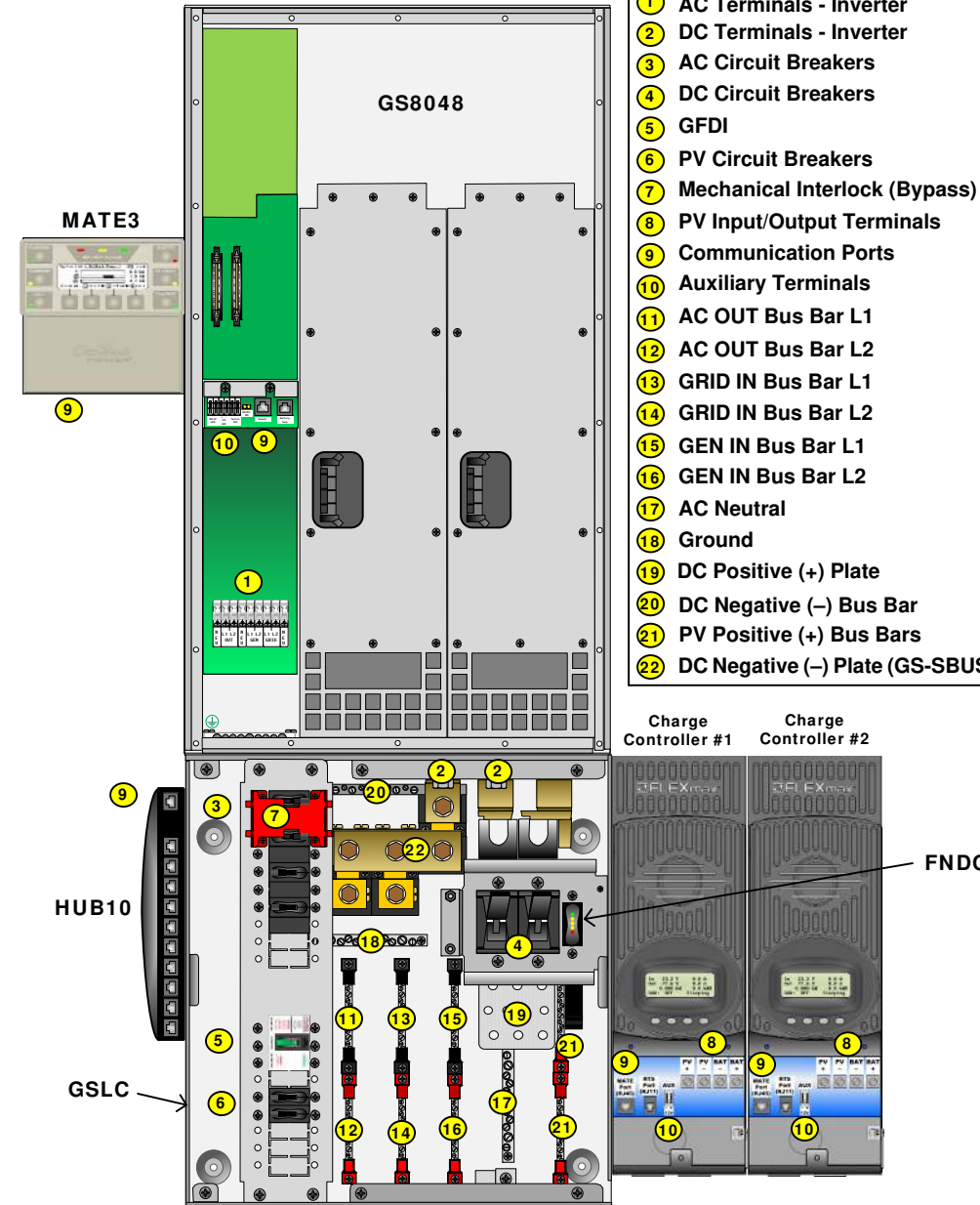
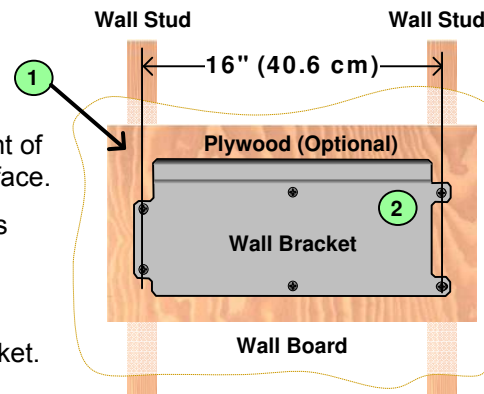
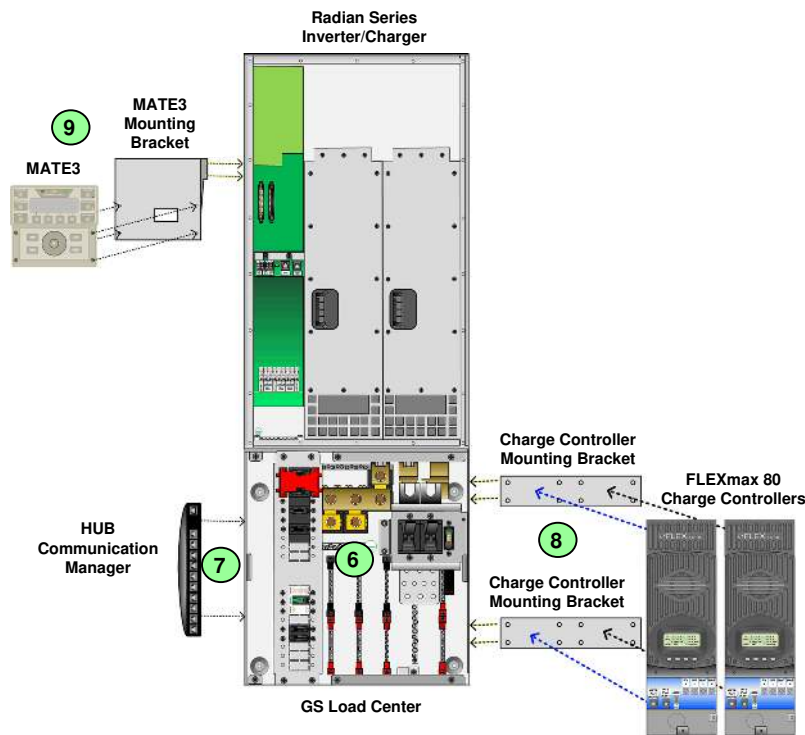
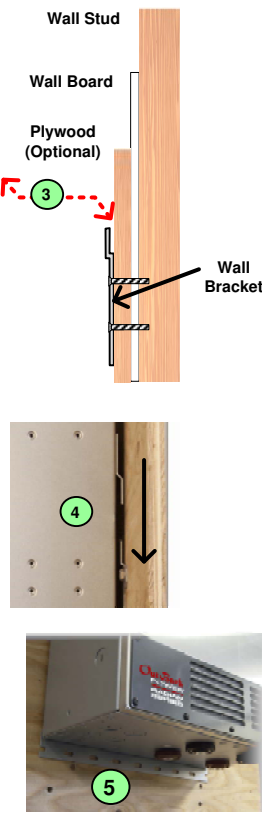

- AC Terminals - Inverter
- DC Terminals - Inverter
- AC Circuit Breakers
- DC Circuit Breakers
- GFDI
- PV Circuit Breakers
- Mechanical Interlock (Bypass)
- PV Input/Output Terminals
- Communication Ports
- Auxiliary Terminals
- AC OUT Bus Bar L1
- AC OUT Bus Bar L2
- GRID IN Bus Bar L1
- GRID IN Bus Bar L2
- GEN IN Bus Bar L1
- GEN IN Bus Bar L2
- AC Neutral
- Ground
- DC Positive (+) Plate
- DC Negative (-) Bus Bar
- PV Positive (+) Bus Bars
- DC Negative (-) Plate (GS-SBUS)

### AC Wire Sizes and Torque Values

Wire Size		Torque	
AWG	mm <sup>2</sup>	In-lb	Nm
#14 - 10	2.5 - 6	20	2.3
#8	10	25	2.8
#6 - 4	16 - 25	35	4.0
#3	35	35	4.0
#2	35	40	4.5
#1	50	50	5.6
1/0	70	50	5.6

It is recommended that conductors be #6 AWG THHN copper, or larger, rated to 75°C (minimum) unless local code requires otherwise.

### Minimum DC Cable based on the DC Circuit Breaker

DC Circuit Breaker	Cable Size	Torque	
		In-lb	Nm
60	#6 AWG (16 mm <sup>2</sup> )	35	4.0
80	#4 AWG (25 mm <sup>2</sup> )	35	4.0
125	1/0 (70 mm <sup>2</sup> )	50	5.6
175	2/0 (70 mm <sup>2</sup> )	225	25.4
250	4/0 (120 mm <sup>2</sup> )	225	25.4

### Torque Requirements

Circuit Breaker Stud	Torque	
	In-lb	Nm
M8	20	2.3
1/4 - 20	35	4.0
5/16 - 18	50	5.6
3/8 - 16	225	25.4
DC Plates		
Upper holes (+)	60	6.8
Lower holes (+)	50	5.6
Shunt Bolts (-) and GS-SBUS	60	6.8

**Control Wiring Terminal Block:**

The Inverter ON/OFF terminals are used for connecting an external ON/OFF switch. To use this feature, the jumper must be removed. (See Radian manual for details.)

The AUX terminals can be used to start a generator or to control external devices.

AUX terminals are also available on the charge controller and the FLEXnet DC. (See the charge controller or FNDC installation manuals for details.)

### CAUTION: Equipment Damage

When connecting cables from the inverter to the battery terminals, ensure the proper polarity is observed. Connecting the cables incorrectly can damage or destroy the equipment and void the product warranty.

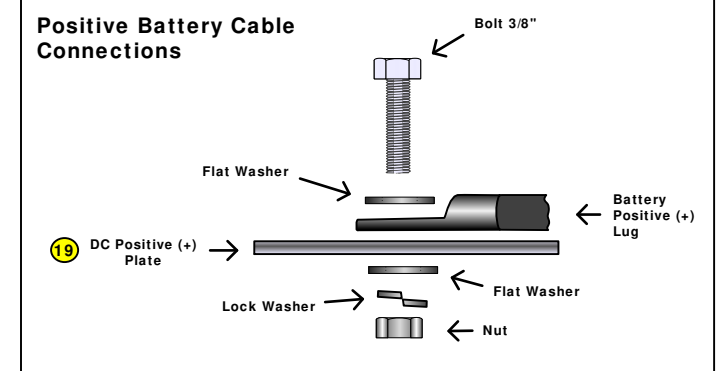
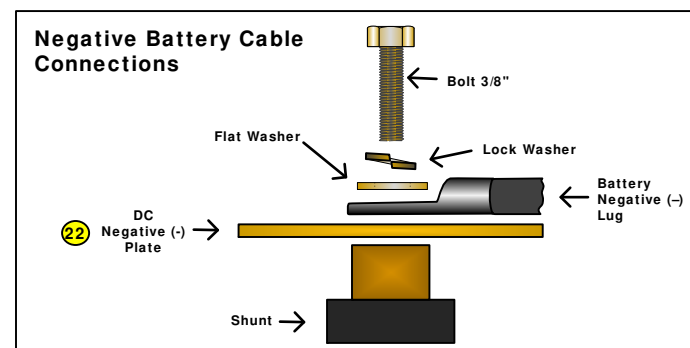



## Pre-startup Procedures:

1. Double-check all wiring connections.
2. Inspect the enclosure to ensure no tools or debris has been left inside.
3. Disconnect all AC loads at the backup (or critical) load panel.
4. Disconnect the AC input feed to the GSLC at the source.

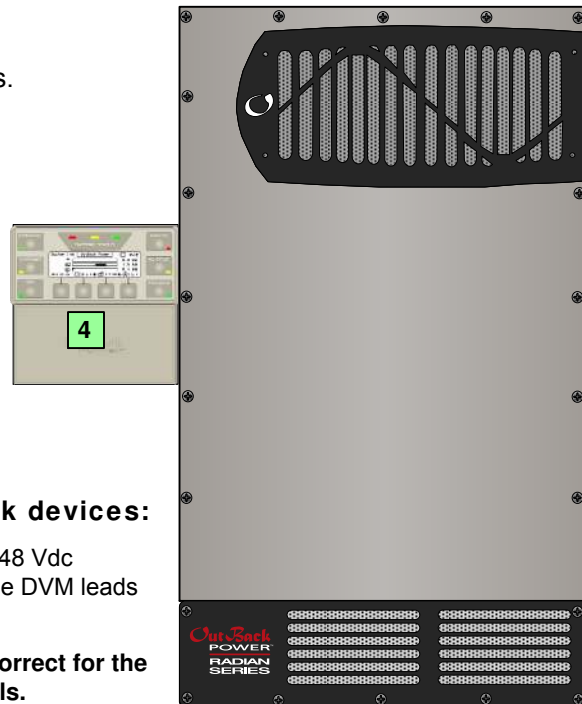

## To energize or start the OutBack devices:

1. Using a digital voltmeter (DVM), verify 48 Vdc on the DC input terminals by placing the DVM leads on (1a) and (1b).

Confirm that the battery voltage is correct for the inverter and charge controller models.

Confirm the polarity.

**CAUTION: Equipment Damage**  
Incorrect polarity will damage the equipment.

2. Turn on (close) the GFDI circuit breaker. **1**
3. Verify that the PV output for each charge controller is in the correct range of open-circuit voltage and confirm the polarity by:
  - a) placing the DVM leads on (2a) and (2b), and
  - b) placing the DVM leads on (2a) and (2c).
4. Turn on (close) the PV input circuit breakers. **2**
5. Turn on (close) the DC circuit breakers from the battery bank to the inverter. **3**
6. If the inverter is in the Off state, turn it On. **4**
7. Verify 120 Vac on the AC Output L1 TBB by placing the DVM leads on (3a) and (3c).
8. Verify 120 Vac on the AC Output L2 TBB (3b) and (3c).
9. Verify 240 Vac between the AC Output TBBs by placing the DVM leads on (3a) and (3b).
10. Turn on (close) the AC output circuit breakers. **5**
11. Start the generator if appropriate. Verify 120/240 Vac on the terminals of the AC input sources.
12. Turn on the AC input feed to the GSLC at the source.
11. Verify 120 Vac on the GRID IN L1 TBB by placing the DVM leads on (4a) and (3c).
12. Verify 120 Vac on the GRID IN L2 TBB (4b) and (3c).
13. Verify 240 Vac between the GRID IN TBBs by placing the DVM leads on (4a) and (4b).
14. Verify 120 Vac on the GEN IN L1 TBB by placing the DVM leads on (5a) and (3c).
15. Verify 120 Vac on the GEN IN L2 TBB (5b) and (3c).
16. Verify 240 Vac between the GEN IN TBBs by placing the DVM leads on (5a) and (5b).
17. Turn on (close) the AC input circuit breakers. **6**
18. Turn on the AC disconnects at the backup (or critical) load panel and test the loads.

## Functional Test Points

<b>Battery Voltage Test Points</b> (1a) (1b)
<b>PV Voltage Test Points</b> (2a) (2b) (2c)
<b>AC OUT Voltage Test Points</b> (Terminal bus bar = TBB) (3a) (3b) (3c)
<b>GRID IN Voltage Test Points</b> (Terminal bus bar = TBB) (4a) (4b) (3c)
<b>GEN IN Voltage Test Points</b> (Terminal bus bar = TBB) (5a) (5b) (3c)

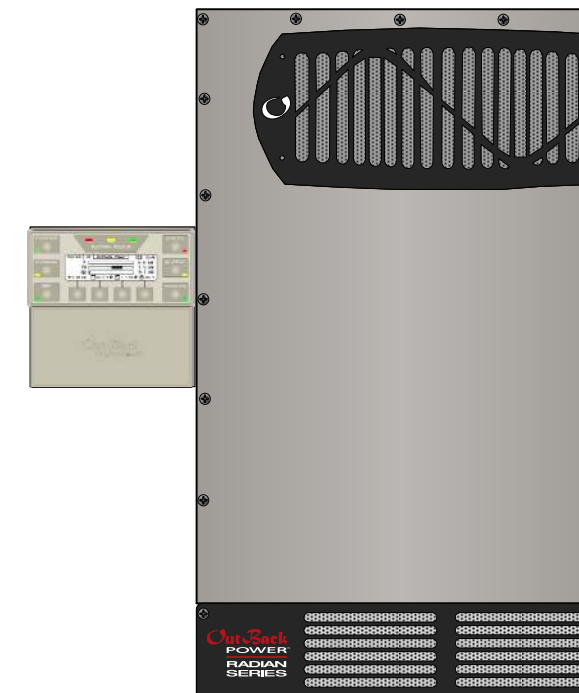
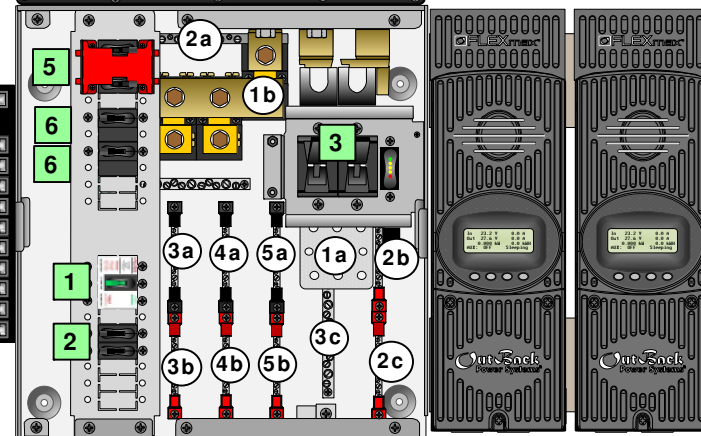

## Functional Test Points

<b>Battery Voltage Test Points</b> (1a) (1b) (1c) (1d)
<b>PV Voltage Test Points</b> (2a) (2b) (2c) (2d) (2e)
<b>AC OUT Voltage Test Points</b> (Terminal bus bar = TBB) (3a) (3b) (3c)

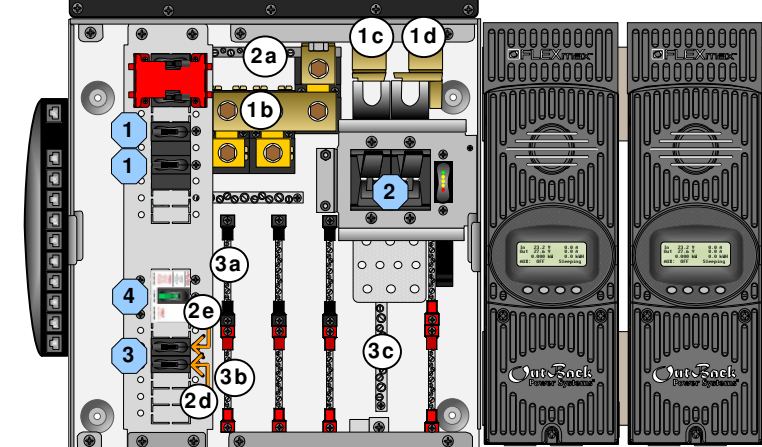

Test points 2d and 2e refer to the right terminal of each circuit breaker.

**WARNING: Burn Hazard**  
Internal parts can become hot during operation. Do not remove the cover during operation or touch any internal parts. Be sure to allow them sufficient time to cool down before attempting to perform any maintenance.

**WARNING: Lethal Voltage**  
Review the system configuration to identify all possible sources of energy. Ensure ALL sources of power are disconnected before performing any installation or maintenance on this equipment. Confirm that the terminals are de-energized using a validated voltmeter (rated for a minimum 1000 Vac and 1000 Vdc) to verify the de-energized condition.

**WARNING: Lethal Voltage**  
The numbered steps will remove power from the inverter and charge controllers. However, sources of energy may still be present inside the GSLC and other locations. To ensure absolute safety, disconnect ALL power connections at the source.

## To de-energize or shut down the OutBack devices:

1. Turn off (open) the AC circuit breakers. **1**
2. Turn off (open) the DC circuit breakers for the battery. **2**  
Wait 5 minutes for the devices to internally discharge themselves.
3. Turn off (open) the PV circuit breakers. **3**
4. Turn off (open) the GFDI circuit breaker. **4**
5. Verify 0 Vdc on the first DC bus of the inverter by placing the voltmeter leads on (1b) and (1c).
6. Verify 0 Vdc on the second DC bus by placing the voltmeter leads on (1b) and (1d).
7. Verify 0 Vdc on one PV circuit by placing the voltmeter leads on (2a) and (2d).
8. Verify 0 Vdc on the other PV circuit by placing the voltmeter leads on (2a) and (2e).
9. Verify 0 Vac on the AC output circuit breakers by placing the voltmeter leads on (3a) and (3c). Repeat this step for (3b) and (3c).

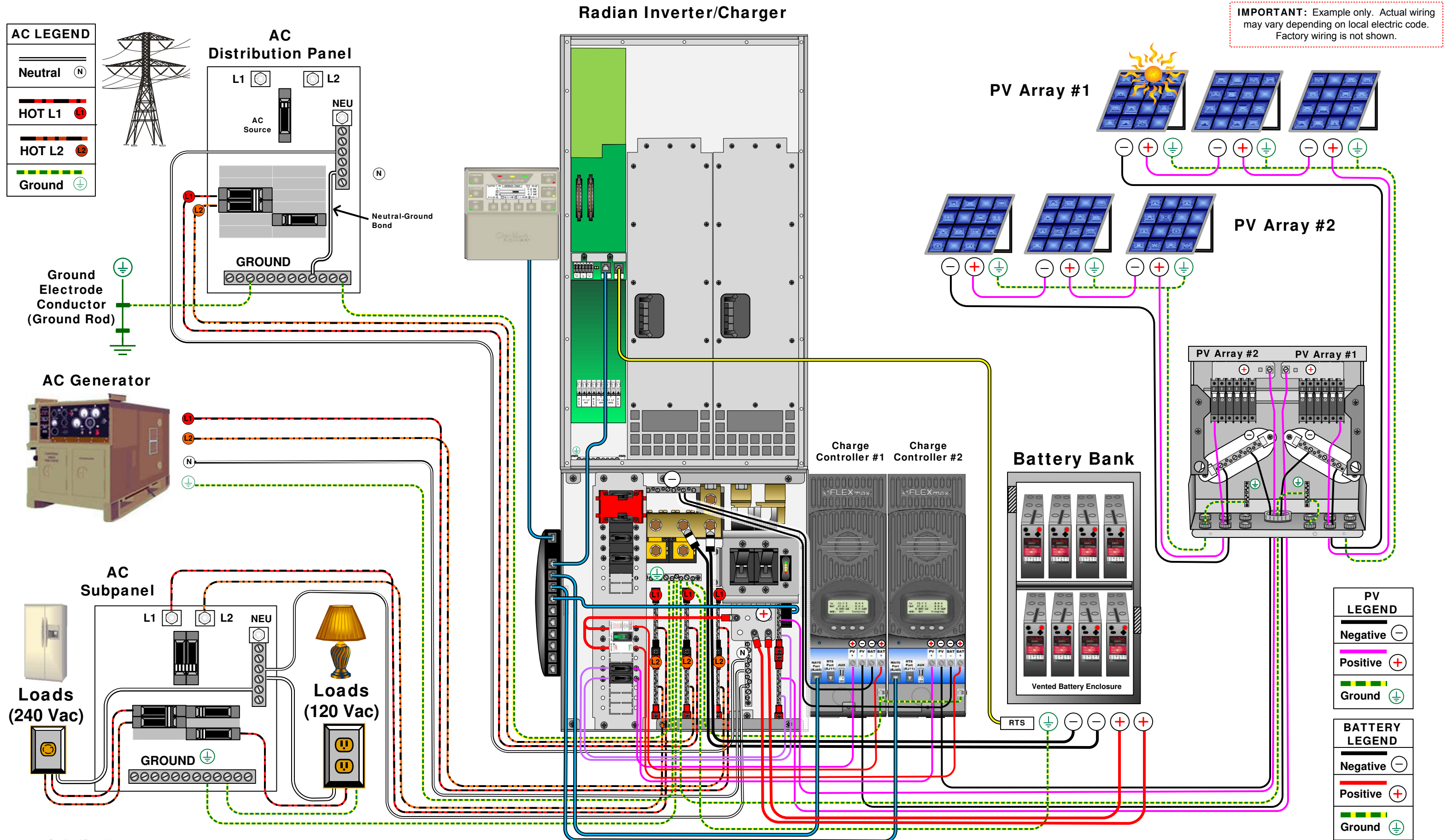

**IMPORTANT:** Example only. Actual wiring may vary depending on local electric code. Factory wiring is not shown.

**AC LEGEND**

Neutral	(N)
HOT L1	(L1)
HOT L2	(L2)
Ground	(⊕)

**PV LEGEND**

Negative	(-)
Positive	(+)
Ground	(⊕)

**BATTERY LEGEND**

Negative	(-)
Positive	(+)
Ground	(⊕)