

ITEM NO	DESCRIPTION	QTY IN KIT
1	CAGENUT, 5/16-18	4
2	FOOT, EXTRUDED L - SLOTTED	8
3	FLANGE HEAD CAP SCREW 5/16-18 X 3/4" SS	4
4	XR10, RAIL 48" (4 FEET) MILL	4
5	T-BOLT BONDING HARDWARE	8
6a, 6b	MICROINVERTER BONDING HARDWARE, T-BOLT	4

Part Number	Description
BX-CMA-SI-M1	BX INVERTER MOUNTING ASSEMBLY (INCL. RAIL AND MOUNTING H/W)

1) Cagenut, 5/16-18

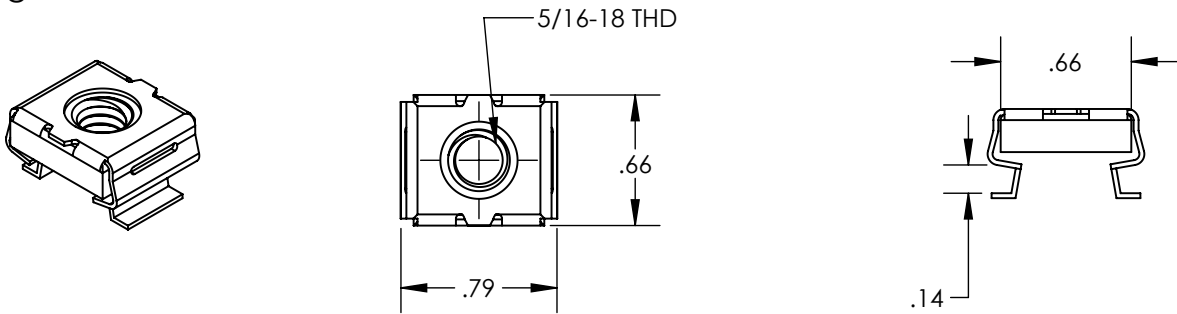

Property	Value
Material	300 Series Stainless Steel
Finish	Clear

2) Foot, Extruded L -Slotted

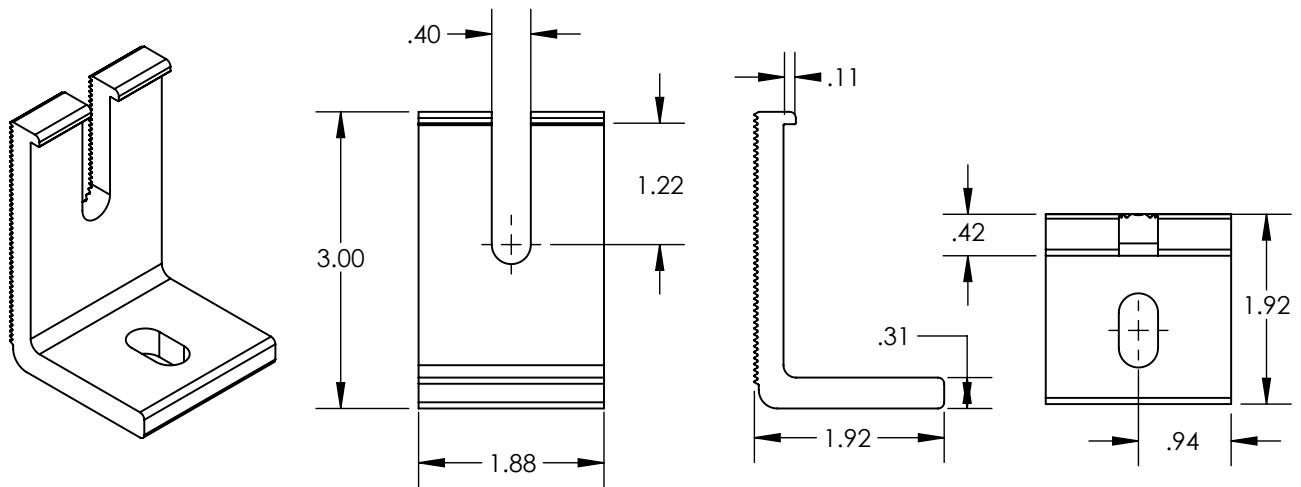

Property	Value
Material	6000 Series Alluminum
Finish	Mill

3) FLANGE HEAD CAP SCREW 5/16-18 X 3/4" SS

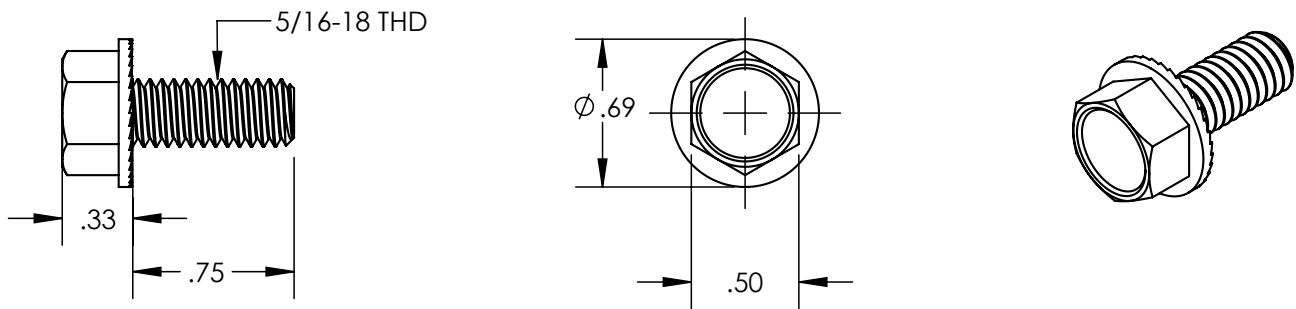

Property	Value
Material	300 Series Stainless Steel
Finish	Clear

4) XR10, Rail 48" (4 feet) Mill

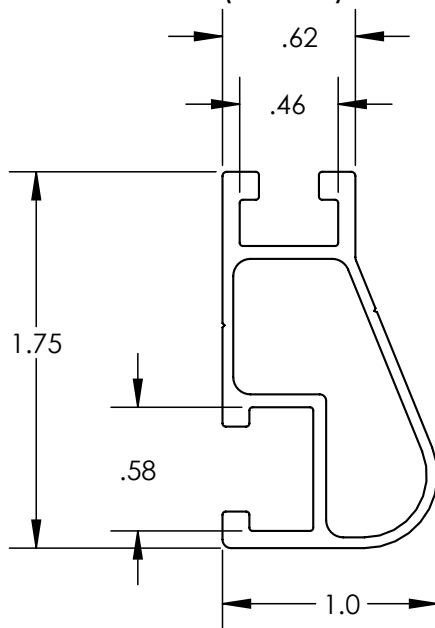

Property	Value
Material	6000 Series Alluminum
Finish	Mill

6) T-Bolt Bonding Hardware

A) BOLT, T CSTM, 3/8-16

B) NUT, BONDING STEP

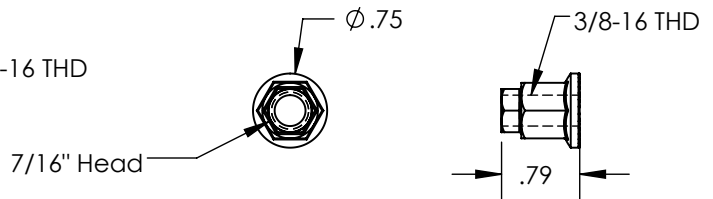
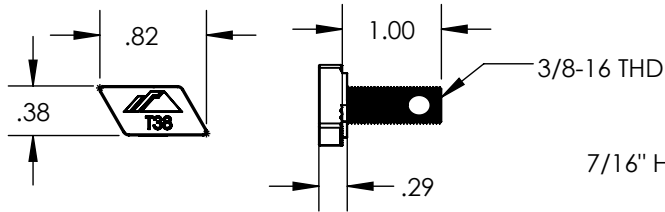
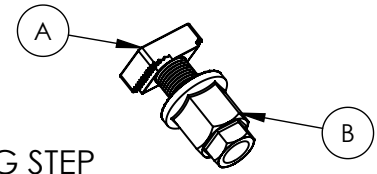

Property	Value
Material	300 Series Stainless Steel
Finish	Clear

Property	Value
Material	300 Series Stainless Steel
Finish	Clear

6) Microinverter Bonding Hardware, T-Bolt

A) Bolt, T CSTM 1/4-20 x .75

B) Nut, Flange Hex 1/4-20

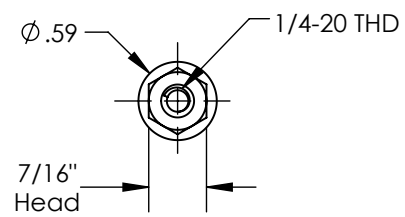
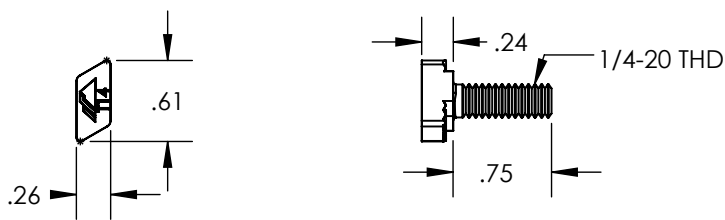
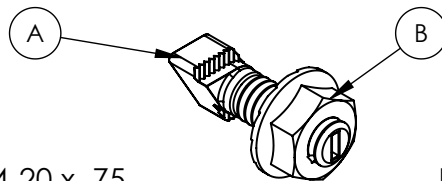

Property	Value
Material	300 Series Stainless Steel
Finish	Clear

Property	Value
Material	300 Series Stainless Steel
Finish	Clear