

Sunmodule® Plus

SW 290 / 300 MONO



Data sheet



HIGH QUALITY ENGINEERING BY SOLARWORLD

More than 40 years of technology expertise, ongoing innovation and continuous optimization create the foundation for the performance of SolarWorld's high-quality modules. We guarantee our customers the highest quality during all steps of production. Our modules are extremely flexible when it comes to their application and provide optimal solutions for installation and non-stop performance – worldwide.

- » Extremely tough and stable, despite its light weight – able to handle loads up to 8.5 kN/m².
- » Tested in extreme weather conditions – hail impact tested and resistant to salt spray, frost, ammonia, dust and sand.
- » Proven guarantee against hotspots and PID- free to IEC 62804-1.
- » Highly-efficient cells (mono PERC) for the highest possible yields.
- » Patented corner design with integrated drainage for optimized self-cleaning.
- » High-transmissive front glass and anti-reflective coating.
- » Long-term safety and guaranteed top performance – At least 97% of nominal power in the first year – 25-year linear performance warranty – 20-year product warranty.



Sunmodule[®] Plus

SW 290 / 300 MONO



PERFORMANCE UNDER STANDARD TEST CONDITIONS (STC)*

		SW 290	SW 300
Maximum power	P_{max}	290 Wp	300 Wp
Open circuit voltage	U_{oc}	39.6 V	40.0 V
Maximum power point voltage	U_{mpp}	31.9 V	32.6 V
Short circuit current	I_{sc}	9.75 A	9.83 A
Maximum power point current	I_{mpp}	9.20 A	9.31 A
Module efficiency	η_m	17.30 %	17.89 %

*STC: 1000W/m², 25°C, AM 1.5

PERFORMANCE AT 800 W/m², NOCT, AM 1.5

		SW 290	SW 300
Maximum power	P_{max}	219.6 Wp	226.7 Wp
Open circuit voltage	U_{oc}	36.7 V	37.0 V
Maximum power point voltage	U_{mpp}	29.5 V	30.2 V
Short circuit current	I_{sc}	7.99 A	8.06 A
Maximum power point current	I_{mpp}	7.43 A	7.52 A

Minor reduction in efficiency under partial load conditions at 25°C: at 200 W/m², 97% (+/-3%) of the STC efficiency (1000 W/m²) is achieved.

PARAMETERS FOR OPTIMAL SYSTEM INTEGRATION

Power sorting	-0 Wp / +10 Wp
Maximum system voltage IEC/ NEC	1000 V / 1000 V
Maximum reverse current	25 A
Number of bypass diodes	3
Operating range	-40°C - +85°C
Maximum Design Loads (Two rail system)*	+5.4 kN/m ² / -3.1 kN/m ²
Maximum Design Loads (Three rail system)*	+8.5 kN/m ² / -3.1 kN/m ²

*Please refer to the Sunmodule Installation instructions for the details associated with these load cases.

COMPONENT MATERIALS

Cells per module	60
Cell type	Mono crystalline PERC
Cell dimensions	156 mm x 156 mm
Front	Tempered safety glass (EN 12150)
Back	Film, white
Frame	Black anodized aluminum
J-Box	IP65
Connector	Amphenol H4 UTX

DIMENSIONS / WEIGHT

Length	1675 mm
Width	1001 mm
Height	33 mm
Weight	18.0 kg

THERMAL CHARACTERISTICS

NOCT	46 °C
TK I_{sc}	0.070 %/K
TK U_{oc}	-0.29 %/K
TK P_{mpp}	-0.39 %/K

ORDERING INFORMATION

Order number	Description
82000482	Sunmodule Plus SW 290 mono
82000432	Sunmodule Plus SW 300 mono

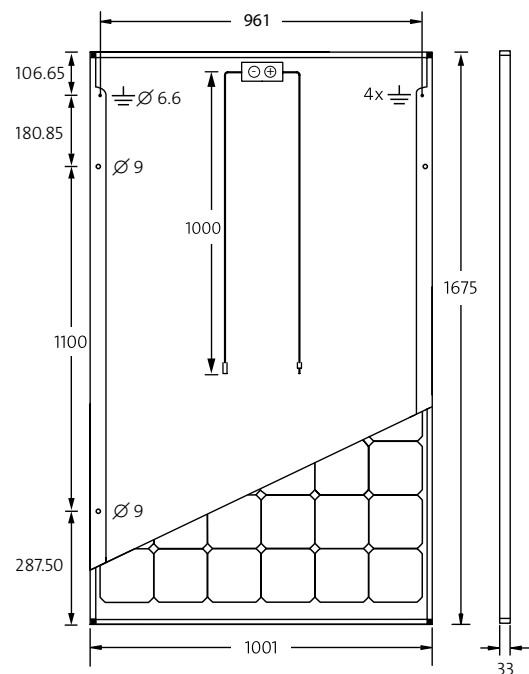

CERTIFICATES AND WARRANTIES

Certificates	IEC 61730	IEC 61215	UL 1703
	IEC 62716	IEC 60068-2-68	IEC 61701
Warranties	Product Warranty	20 years	
	Linear Performance Guarantee	25 years	