

# Installation

## Residential/Commercial Generator Sets



Models:

**8/10/12RESV**  
**8/10/12RESVL**

Controllers:

RDC2  
DC2

**KOHLER**  
Power Systems

**ISO 9001**  
**KOHLER**  
POWER SYSTEMS  
NATIONALLY REGISTERED

TP-6879 3/15a

---

**California Proposition 65**

** WARNING**

Engine exhaust from this product contains chemicals known to the State of California to cause cancer, birth defects, or other reproductive harm.

---

## Product Identification Information

---

### Generator Set Identification Numbers

Record the product identification numbers from the generator set nameplate(s).

Model Designation \_\_\_\_\_

Specification Number \_\_\_\_\_

Serial Number \_\_\_\_\_

<b>Accessory Number</b>	<b>Accessory Description</b>
-------------------------	------------------------------

_____	_____
-------	-------

_____	_____
-------	-------

_____	_____
-------	-------

_____	_____
-------	-------

_____	_____
-------	-------

### Engine Identification

Record the product identification information from the engine nameplate.

Manufacturer \_\_\_\_\_

Model Designation \_\_\_\_\_

Serial Number \_\_\_\_\_

### Controller Identification

Record the controller description from the generator set operation manual, spec sheet, or sales invoice.

Controller Description \_\_\_\_\_

# Table of Contents

<b>Safety Precautions and Instructions</b> .....	<b>5</b>
<b>Introduction</b> .....	<b>9</b>
Startup and Registration .....	9
<b>Service Assistance</b> .....	<b>10</b>
<b>Section 1 Installation</b> .....	<b>11</b>
1.1 Introduction .....	11
1.2 Lifting .....	12
1.3 Generator Set Inspection .....	12
1.4 Location and Mounting .....	12
1.4.1 Mounting Area .....	12
1.4.2 Exhaust Requirements .....	13
1.5 Dimension Drawings .....	13
1.6 Access the Air Intake Area .....	13
1.7 Fuel Requirements .....	14
1.7.1 Fuel Supply .....	14
1.7.2 Fuel Pipe Size .....	14
1.7.3 Connecting the Fuel Supply .....	15
1.8 Fuel Conversion .....	16
1.9 Electrical Connections .....	18
1.9.1 Grounding .....	19
1.9.2 Electrical Lead Entry .....	19
1.9.3 Field-Connection Terminal Block .....	19
1.9.4 AC Power Supply .....	20
1.10 ATS and Accessory Connections .....	21
1.10.1 Transfer Switch Connection .....	21
1.10.2 Communication Cable Specifications .....	23
1.10.3 System Connections with Accessory Modules .....	24
1.11 Battery .....	28
1.12 Prestart Installation Check .....	29
1.13 Set the Exerciser .....	30
1.13.1 RDC2 Controller .....	30
1.13.2 DC2 Controller .....	30
1.13.3 Loaded Exercise .....	30
1.14 Operation Test .....	30
1.15 OnCue Plus Generator Management System .....	31
<b>Section 2 Accessories</b> .....	<b>33</b>
2.1 Introduction .....	33
2.2 Connect Optional Programmable Interface Module (PIM) .....	33
2.3 Load Control Module (LCM) .....	34
2.4 Load Shed Kit .....	35
2.4.1 Special Equipment .....	35
2.5 Carburetor Heater .....	36
<b>Section 3 Drawings and Diagrams</b> .....	<b>37</b>
Appendix A Abbreviations .....	43

# Notes

# Safety Precautions and Instructions

IMPORTANT SAFETY INSTRUCTIONS. Electromechanical equipment, including generator sets, transfer switches, switchgear, and accessories, can cause bodily harm and pose life-threatening danger when improperly installed, operated, or maintained. To prevent accidents be aware of potential dangers and act safely. Read and follow all safety precautions and instructions. **SAVE THESE INSTRUCTIONS.**

This manual has several types of safety precautions and instructions: Danger, Warning, Caution, and Notice.

## DANGER

Danger indicates the presence of a hazard that **will cause severe personal injury, death, or substantial property damage.**

## WARNING

Warning indicates the presence of a hazard that **can cause severe personal injury, death, or substantial property damage.**

## CAUTION

Caution indicates the presence of a hazard that **will or can cause minor personal injury or property damage.**

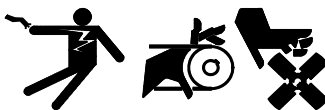
## NOTICE

Notice communicates installation, operation, or maintenance information that is safety related but not hazard related.

Safety decals affixed to the equipment in prominent places alert the operator or service technician to potential hazards and explain how to act safely. The decals are shown throughout this publication to improve operator recognition. Replace missing or damaged decals.

## Accidental Starting

### WARNING



**Accidental starting.  
Can cause severe injury or death.**

Disconnect the battery cables before working on the generator set. Remove the negative (-) lead first when disconnecting the battery. Reconnect the negative (-) lead last when reconnecting the battery.

**Disabling the generator set. Accidental starting can cause severe injury or death.** Before working on the generator set or equipment connected to the set, disable the generator set as follows: (1) Press the generator set off/reset button to shut down the generator set. (2) Disconnect the power to the battery charger, if equipped. (3) Remove the battery cables, negative (-) lead first. Reconnect the negative (-) lead last when reconnecting the battery. Follow these precautions to prevent the starting of the generator set by the remote start/stop switch.

## Battery

### WARNING



**Sulfuric acid in batteries.  
Can cause severe injury or death.**

Wear protective goggles and clothing. Battery acid may cause blindness and burn skin.

### WARNING



**Explosion.  
Can cause severe injury or death.  
Relays in the battery charger  
cause arcs or sparks.**

Locate the battery in a well-ventilated area. Isolate the battery charger from explosive fumes.


**Battery electrolyte is a diluted sulfuric acid. Battery acid can cause severe injury or death.** Battery acid can cause blindness and burn skin. Always wear splashproof safety goggles, rubber gloves, and boots when servicing the battery. Do not open a sealed battery or mutilate the battery case. If battery acid splashes in the eyes or on the skin, immediately flush the affected area for 15 minutes with large quantities of clean water. Seek immediate medical aid in the case of eye contact. Never add acid to a battery after placing the battery in service, as this may result in hazardous spattering of battery acid.

**Battery acid cleanup. Battery acid can cause severe injury or death.** Battery acid is electrically conductive and corrosive. Add 500 g (1 lb.) of bicarbonate of soda (baking soda) to a container with 4 L (1 gal.) of water and mix the neutralizing solution. Pour the neutralizing solution on the spilled battery acid and continue to add the neutralizing solution to the spilled battery acid until all evidence of a chemical reaction (foaming) has ceased. Flush the resulting liquid with water and dry the area.

**Battery gases. Explosion can cause severe injury or death.** Battery gases can cause an explosion. Do not smoke or permit flames or sparks to occur near a battery at any time, particularly when it is charging. Do not dispose of a battery in a fire. To prevent burns and sparks that could cause an explosion, avoid touching the battery terminals with tools or other metal objects. Remove all jewelry before servicing the equipment. Discharge static electricity from your body before touching batteries by first touching a grounded metal surface away from the battery. To avoid sparks, do not disturb the battery charger connections while the battery is charging. Always turn the battery charger off before disconnecting the battery connections. Ventilate the compartments containing batteries to prevent accumulation of explosive gases.

**Battery short circuits. Explosion can cause severe injury or death.** Short circuits can cause bodily injury and/or equipment damage. Disconnect the battery before generator set installation or maintenance. Remove all jewelry before servicing the equipment. Use tools with insulated handles. Remove the negative (-) lead first when disconnecting the battery. Reconnect the negative (-) lead last when reconnecting the battery. Never connect the negative (-) battery cable to the positive (+) connection terminal of the starter solenoid. Do not test the battery condition by shorting the terminals together.

## Engine Backfire/Flash Fire

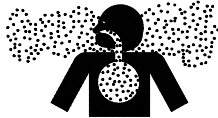
<b>⚠ WARNING</b>

<b>Fire.</b> <b>Can cause severe injury or death.</b>
Do not smoke or permit flames or sparks near fuels or the fuel system.

**Servicing the air cleaner. A sudden backfire can cause severe injury or death.** Do not operate the generator set with the air cleaner removed.

**Servicing the fuel system. A flash fire can cause severe injury or death.** Do not smoke or permit flames or sparks near the carburetor, fuel line, fuel filter, fuel pump, or other potential sources of spilled fuels or fuel vapors. Catch fuels in an approved container when removing the fuel line or carburetor.

**Combustible materials. A fire can cause severe injury or death.** Generator set engine fuels and fuel vapors are flammable and explosive. Handle these materials carefully to minimize the risk of fire or explosion. Equip the compartment or nearby area with a fully charged fire extinguisher. Select a fire extinguisher rated ABC or BC for electrical fires or as recommended by the local fire code or an authorized agency. Train all personnel on fire extinguisher operation and fire prevention procedures.

## Exhaust System

<b>⚠ WARNING</b>

<b>Carbon monoxide.</b> <b>Can cause severe nausea, fainting, or death.</b>
The exhaust system must be leakproof and routinely inspected.

**Generator set operation. Carbon monoxide can cause severe nausea, fainting, or death.** Carbon monoxide is an odorless, colorless, tasteless, nonirritating gas that can cause death if inhaled for even a short time. Avoid breathing exhaust fumes when working on or near the generator set. Never operate the generator set inside a building. Never operate the generator set where exhaust gas could seep inside or be drawn into a potentially occupied building through windows, air intake vents, or other openings.

**Carbon monoxide detectors. Carbon monoxide can cause severe nausea, fainting, or death.** Install carbon monoxide detectors on each level of any building adjacent to the generator set. Locate the detectors to adequately warn the building's occupants of the presence of carbon monoxide. Keep the detectors operational at all times. Periodically test and replace the carbon monoxide detectors according to the manufacturer's instructions.

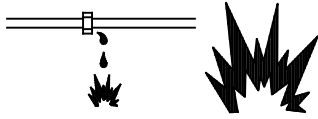
**Carbon monoxide symptoms. Carbon monoxide can cause severe nausea, fainting, or death.** Carbon monoxide is a poisonous gas present in exhaust gases. Carbon monoxide is an odorless, colorless, tasteless, nonirritating gas that can cause death if inhaled for even a short time. Carbon monoxide poisoning symptoms include but are not limited to the following:

- Light-headedness, dizziness
- Physical fatigue, weakness in joints and muscles
- Sleepiness, mental fatigue, inability to concentrate or speak clearly, blurred vision
- Stomachache, vomiting, nausea

If experiencing any of these symptoms and carbon monoxide poisoning is possible, seek fresh air immediately and remain active. Do not sit, lie down, or fall asleep. Alert others to the possibility of carbon monoxide poisoning. Seek medical attention if the condition of affected persons does not improve within minutes of breathing fresh air.

## Fuel System

### ⚠ WARNING



**Explosive fuel vapors. Can cause severe injury or death.**

Use extreme care when handling, storing, and using fuels.

**The fuel system. Explosive fuel vapors can cause severe injury or death.** Vaporized fuels are highly explosive. Use extreme care when handling and storing fuels. Store fuels in a well-ventilated area away from spark-producing equipment and out of the reach of children. Never add fuel to the tank while the engine is running because spilled fuel may ignite on contact with hot parts or from sparks. Do not smoke or permit flames or sparks to occur near sources of spilled fuel or fuel vapors. Keep the fuel lines and connections tight and in good condition. Do not replace flexible fuel lines with rigid lines. Use flexible sections to avoid fuel line breakage caused by vibration. Do not operate the generator set in the presence of fuel leaks, fuel accumulation, or sparks. Repair fuel systems before resuming generator set operation.

**Gas fuel leaks. Explosive fuel vapors can cause severe injury or death.** Fuel leakage can cause an explosion. Check the LP vapor gas or natural gas fuel system for leakage by using a soap and water solution with the fuel system test pressurized to 6–8 ounces per square inch (10–14 inches water column). Do not use a soap solution containing either ammonia or chlorine because both prevent bubble formation. A successful test depends on the ability of the solution to bubble.

## Hazardous Noise

### ⚠ CAUTION



**Hazardous noise. Can cause hearing loss.**

Never operate the generator set without a muffler or with a faulty exhaust system.

**Engine noise. Hazardous noise can cause hearing loss.** Generator sets not equipped with sound enclosures can produce noise levels greater than 105 dBA. Prolonged exposure to noise levels greater than 85 dBA can cause permanent hearing loss. Wear hearing protection when near an operating generator set.

## Hazardous Voltage/ Moving Parts

### ⚠ DANGER



**Hazardous voltage. Will cause severe injury or death.**

This equipment must be installed and serviced by qualified electrical personnel.

### ⚠ WARNING



**Hazardous voltage. Moving parts. Can cause severe injury or death.**

Operate the generator set only when all guards and electrical enclosures are in place.

### ⚠ WARNING



**Hazardous voltage. Backfeed to the utility system can cause property damage, severe injury, or death.**

If the generator set is used for standby power, install an automatic transfer switch to prevent inadvertent interconnection of standby and normal sources of supply.

### ⚠ CAUTION



**Welding the generator set. Can cause severe electrical equipment damage.**

Never weld components of the generator set without first disconnecting the battery, controller wiring harness, and engine electronic control module (ECM).

**Grounding electrical equipment. Hazardous voltage can cause severe injury or death.** Electrocutation is possible whenever electricity is present. Ensure you comply with all applicable codes and standards. Electrically ground the generator set, transfer switch, and related equipment and electrical circuits. Turn off the main circuit breakers of all power sources before servicing the equipment. Never contact electrical leads or appliances when standing in water or on wet ground because these conditions increase the risk of electrocution.



**Welding on the generator set. Can cause severe electrical equipment damage.** Before welding on the generator set perform the following steps: (1) Remove the battery cables, negative (-) lead first. (2) Disconnect all engine electronic control module (ECM) connectors. (3) Disconnect all generator set controller and voltage regulator circuit board connectors. (4) Disconnect the engine battery-charging alternator connections. (5) Attach the weld ground connection close to the weld location.

**Connecting the battery and the battery charger. Hazardous voltage can cause severe injury or death.** Reconnect the battery correctly, positive to positive and negative to negative, to avoid electrical shock and damage to the battery charger and battery(ies). Have a qualified electrician install the battery(ies).



**Short circuits. Hazardous voltage/current can cause severe injury or death.** Short circuits can cause bodily injury and/or equipment damage. Do not contact electrical connections with tools or jewelry while making adjustments or repairs. Remove all jewelry before servicing the equipment.

**Electrical backfeed to the utility. Hazardous backfeed voltage can cause severe injury or death.** Install a transfer switch in standby power installations to prevent the connection of standby and other sources of power. Electrical backfeed into a utility electrical system can cause severe injury or death to utility personnel working on power lines.

## Heavy Equipment

 <b>WARNING</b>

<p><b>Unbalanced weight. Improper lifting can cause severe injury or death and equipment damage.</b></p> <p>Do not use lifting eyes. Lift the generator set using lifting bars inserted through the lifting holes on the skid.</p>

## Hot Parts

 <b>WARNING</b>

<p><b>Hot engine and exhaust system. Can cause severe injury or death.</b></p> <p>Do not work on the generator set until it cools.</p>

**Servicing the exhaust system. Hot parts can cause severe injury or death.** Do not touch hot engine parts. The engine and exhaust system components become extremely hot during operation.

**Servicing the engine heater. Hot parts can cause minor personal injury or property damage.** Install the heater before connecting it to power. Operating the heater before installation can cause burns and component damage. Disconnect power to the heater and allow it to cool before servicing the heater or nearby parts.

## Notice

### NOTICE

**Canadian installations only.** For standby service connect the output of the generator set to a suitably rated transfer switch in accordance with Canadian Electrical Code, Part 1.



This manual provides installation instructions for Model 8/10/12RESV or 8/10/12RESVL generator sets. See Figure 1. Refer to TP-6880, Operation Manual, for generator set operation and maintenance instructions.

The generator set is approved for use in stationary applications in locations served by a reliable utility power source.

Have a Kohler® authorized distributor/dealer install the generator set outdoors according to the instructions in this manual. The generator set installation must comply with the National Electrical Code (NEC) and local code requirements. Do not install this generator set indoors.

Information in this publication represents data available at the time of print. Kohler Co. reserves the right to change this publication and the products represented without notice and without any obligation or liability whatsoever.

Read this manual and carefully follow all procedures and safety precautions to ensure proper equipment operation and to avoid bodily injury. Read and follow the Safety Precautions and Instructions section at the beginning of this manual.



**Figure 1** Model RESV Generator Set

## List of Related Literature

Figure 2 identifies related literature available for the generator sets covered in this manual. Only trained and qualified personnel should install or service the generator set.

Literature Type	Part Number
OperationManual, Generator Set	TP-6880
Operation/Installation Manual, Model RXT Automatic Transfer Switch	TP-6807
Service Manual, Generator Set	TP-6735
Operation Manual, OnCue® Plus Software	TP-6928
Operation Manual, SiteTech™ Software	TP-6701
Operation/Installation Manual, Model RDT Transfer Switch	TP-6345
Installation Manual, Model RSB Transfer Switch	TP-6486
Operation Manual, Model RSB Transfer Switch	TP-6487
Installation Instructions, Load Control Module (LCM)	TT-1574
Installation Instructions, Programmable Interface Module (PIM)	TT-1584
Installation Instructions, Load Shed Kit	TT-1609
Installation Instructions, USB Utility	TT-1636

**Figure 2** Related Literature

## Startup and Registration

When the generator set is installed, complete the startup and installation checklists supplied with the startup notification form. Complete the startup notification form and register the unit using the Kohler online Warranty Processing System.

For professional advice on generator set power requirements and conscientious service, please contact your nearest Kohler distributor or dealer.

- Consult the Yellow Pages under the heading Generators—Electric.
- Visit the Kohler Power Systems website at KOHLERPower.com.
- Look at the labels and stickers on your Kohler product or review the appropriate literature or documents included with the product.
- Call toll free in the US and Canada 1-800-544-2444.
- Outside the US and Canada, call the nearest regional office.

## **Headquarters Europe, Middle East, Africa (EMEA)**

Kohler Power Systems Netherlands B.V.  
Kristallaan 1  
4761 ZC Zevenbergen  
The Netherlands  
Phone: (31) 168 331630  
Fax: (31) 168 331631

## **Asia Pacific**

Power Systems Asia Pacific Regional Office  
Singapore, Republic of Singapore  
Phone: (65) 6264-6422  
Fax: (65) 6264-6455

## **China**

North China Regional Office, Beijing  
Phone: (86) 10 6518 7950  
(86) 10 6518 7951  
(86) 10 6518 7952  
Fax: (86) 10 6518 7955

East China Regional Office, Shanghai  
Phone: (86) 21 6288 0500  
Fax: (86) 21 6288 0550

## **India, Bangladesh, Sri Lanka**

India Regional Office  
Bangalore, India  
Phone: (91) 80 3366208  
(91) 80 3366231  
Fax: (91) 80 3315972


## **Japan, Korea**

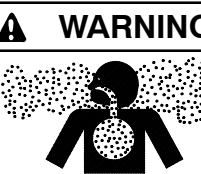
North Asia Regional Office  
Tokyo, Japan  
Phone: (813) 3440-4515  
Fax: (813) 3440-2727

## **Latin America**

Latin America Regional Office  
Lakeland, Florida, USA  
Phone: (863) 619-7568  
Fax: (863) 701-7131

## 1.1 Introduction


<b>Hazardous voltage.</b> <b>Will cause severe injury or death.</b>
This equipment must be installed and serviced by qualified electrical personnel.


<b>Carbon monoxide.</b> <b>Can cause severe nausea, fainting, or death.</b>
The exhaust system must be leakproof and routinely inspected.

**Generator set operation. Carbon monoxide can cause severe nausea, fainting, or death.** Carbon monoxide is an odorless, colorless, tasteless, nonirritating gas that can cause death if inhaled for even a short time. Avoid breathing exhaust fumes when working on or near the generator set. Never operate the generator set inside a building. Never operate the generator set where exhaust gas could seep inside or be drawn into a potentially occupied building through windows, air intake vents, or other openings.

**Carbon monoxide detectors. Carbon monoxide can cause severe nausea, fainting, or death.** Install carbon monoxide detectors on each level of any building adjacent to the generator set. Locate the detectors to adequately warn the building's occupants of the presence of carbon monoxide. Keep the detectors operational at all times. Periodically test and replace the carbon monoxide detectors according to the manufacturer's instructions.

Have the generator set installed by an authorized Kohler distributor/dealer or authorized representative. Install the equipment in compliance with the National Electrical Code (NEC) and local codes. For Canadian installations, refer to the Canadian Electrical Code (CEC).

The generator set must be installed outdoors. The exhaust systems on enclosed units are designed for outdoor installation only.

**Note: DO NOT** install these generator sets inside a building.

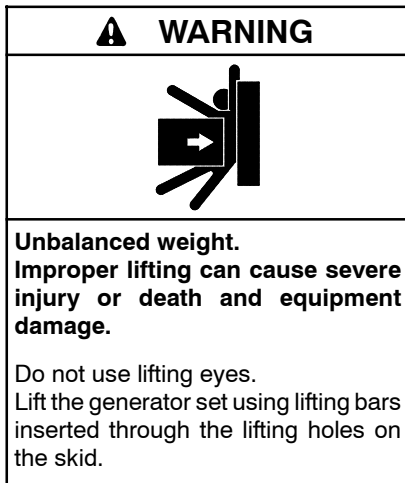
**Note:** Install carbon monoxide (CO) detector(s) on each level of any building adjacent to a generator set. Locate the detectors to adequately warn the building's occupants of the presence of carbon monoxide.

Obtain a building permit and contact your local utility companies to mark the locations of underground pipes and cables.

Read and follow the safety precautions in this manual and observe the decals on the equipment. Refer to the diagrams and drawings in this manual for dimensions and electrical connections during the installation procedure. Read the entire installation procedure and obtain the accessories and tools needed before beginning installation. Perform the steps in the order shown.

To install optional accessories, follow the instructions provided with each kit.

## 1.2 Lifting



Approximate generator set weights are shown in Figure 1-1. Use lifting bars inserted through the holes in the skid to lift the unit. See the dimension drawings in Section 3 for lifting hole locations.

Model	Weight, kg (lb.)
8RESV/RESVL	170 (375)
10RESV/RESVL	194 (428)
12RESV/RESVL	196 (433)

**Figure 1-1** Approximate Shipping Weights

## 1.3 Generator Set Inspection

Complete a thorough inspection of the generator set. Check for the following:

1. Inspect the generator set for loose or damaged parts or wires. Repair or tighten any loose parts before installation.
2. Check the engine oil. Fill, if necessary, with the recommended viscosity and grade of oil. Use synthetic oil, API (American Petroleum Institute) Service Class SG or higher. See TP-6880, Operation Manual, for additional information.

## 1.4 Location and Mounting

Install the generator set outdoors near the incoming gas service. The generator set location must allow easy access for maintenance and service. The recommended distance from a structure is dependent on state and local codes. See the dimension drawing in Section 3 for the recommended clearance from structures and non-combustible materials.

Locate the generator set so that the hot exhaust does not blow on plants or other combustible materials. No plants, shrubs, or other combustible materials are allowed within 1.2 m (4 ft.) of the exhaust end of the generator set.

Do not install the generator set where exhaust gas could accumulate and seep inside or be drawn into a potentially occupied building. Furnace and other similar intakes must be at least 3 m (10 ft.) from the exhaust end of the generator set.

### Notice

**DO NOT** locate the generator set near patios, decks, play areas, or animal shelters. Keep items such as lawn furniture, toys, sports equipment, and all combustible materials away from the generator set exhaust outlet.

Remind family members, children, and visitors to use caution near the generator set. Generator sets connected to automatic transfer switches start automatically during exercise periods and power outages. Some generator set components become hot when the generator set is running and remain hot for a time after the generator set shuts down.

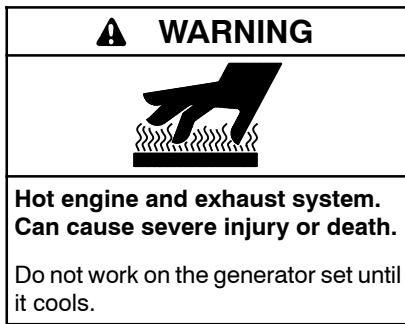
### 1.4.1 Mounting Area

The generator set is shipped on a wooden pallet. Remove the wooden pallet before positioning the generator set. Prepare a flat, level mounting area covered with a weed barrier and gravel or a concrete mounting pad. Set the generator set directly on the gravel or concrete.

**Note:** When installing a concrete mounting pad, the generator set must be secured to the mounting pad to prevent shifting or movement caused by engine vibration. Use the screw inserts in the mounting pad to secure the generator set. See TT-1619 for concrete mounting pad installation instructions.

Do not install the generator set directly on grass, wood, or other combustible materials. Clear all combustible materials, including plants and shrubs, building materials, and lawn furniture, from an area at least 1.2 m (4 ft.) beyond the exhaust end of the generator set. See the dimension drawing in Section 3.

## 1.4.2 Exhaust Requirements



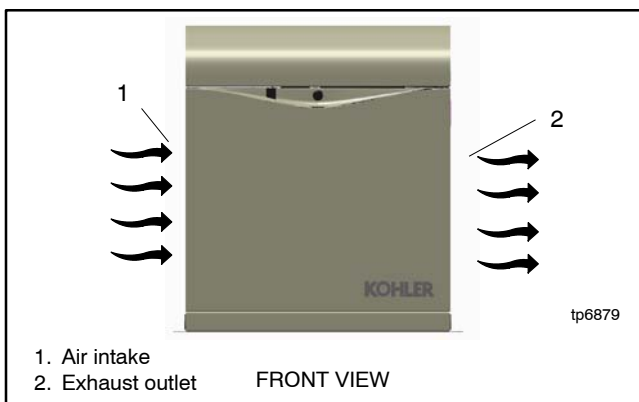
**Servicing the exhaust system. Hot parts can cause severe injury or death.** Do not touch hot engine parts. The engine and exhaust system components become extremely hot during operation.

Figure 1-2 gives the exhaust temperature at rated load. Mount the generator set so that the hot exhaust does not blow on plants or other combustible materials. Maintain the clearances shown in the dimension drawing in Section 3.

Exhaust	Model	Temperature, °C (°F)
Exhaust gas exiting the enclosure at rated kW, °C (°F)	8RESV(L)	190 (374)
	10/12RESV(L)	106 (224)

**Figure 1-2** Exhaust Flow and Temperature

The generator set requires correct air flow for cooling and combustion. The inlet and outlet openings in the sound enclosure provide the cooling and combustion air. Figure 1-3 shows the locations of the cooling air intake and exhaust vents. Inspect the air inlet and outlet openings inside and outside the housing to ensure that the air flow is not blocked.



**Figure 1-3** Cooling Air Intake and Exhaust

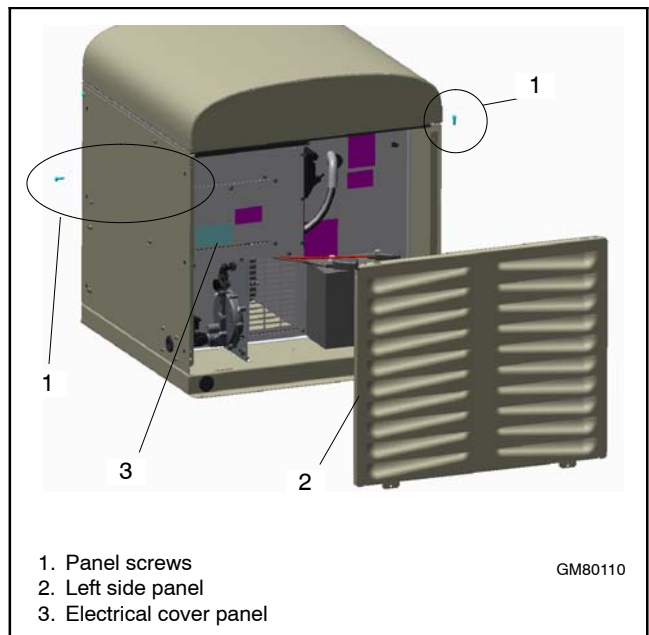
## 1.5 Dimension Drawings

See the dimension drawings in Section 3 for the generator set dimensions, fuel and electric inlet locations, and recommended clearance.

## 1.6 Access the Air Intake Area

The battery, fuel system, and electrical connections are located in the air intake area. Raise the roof and remove the enclosure panel to access the air intake area during installation as described below.

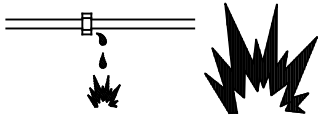
1. Remove panel screws and remove the panel. Pull the panel up and off. See Figure 1-4.
2. To make the electrical connections, you will also need to remove the cover panel over the terminal block.
3. Reinstall the panels after all electrical connections are complete and the battery is installed and connected.



**Figure 1-4** Remove Left Panel

## 1.7 Fuel Requirements

### WARNING



**Explosive fuel vapors.  
Can cause severe injury or death.**

Use extreme care when handling, storing, and using fuels.

**The fuel system. Explosive fuel vapors can cause severe injury or death.** Vaporized fuels are highly explosive. Use extreme care when handling and storing fuels. Store fuels in a well-ventilated area away from spark-producing equipment and out of the reach of children. Never add fuel to the tank while the engine is running because spilled fuel may ignite on contact with hot parts or from sparks. Do not smoke or permit flames or sparks to occur near sources of spilled fuel or fuel vapors. Keep the fuel lines and connections tight and in good condition. Do not replace flexible fuel lines with rigid lines. Use flexible sections to avoid fuel line breakage caused by vibration. Do not operate the generator set in the presence of fuel leaks, fuel accumulation, or sparks. Repair fuel systems before resuming generator set operation.

**Gas fuel leaks. Explosive fuel vapors can cause severe injury or death.** Fuel leakage can cause an explosion. Check the LP vapor gas or natural gas fuel system for leakage by using a soap and water solution with the fuel system test pressurized to 6–8 ounces per square inch (10–14 inches water column). Do not use a soap solution containing either ammonia or chlorine because both prevent bubble formation. A successful test depends on the ability of the solution to bubble.

**Explosive fuel vapors can cause severe injury or death.** Take additional precautions when using the following fuels:

**Propane (LP)**—Adequate ventilation is mandatory. Because propane is heavier than air, install propane gas detectors low in a room. Inspect the detectors per the manufacturer's instructions.

**Natural Gas**—Adequate ventilation is mandatory. Because natural gas rises, install natural gas detectors high in a room. Inspect the detectors per the manufacturer's instructions.

The generator set operates using natural gas or LPG fuel. The generator set is EPA-certified for both natural gas and LPG fuels.

The fuel system installation must comply with the NEC and local codes.

### 1.7.1 Fuel Supply

Because of variable climates and geographical considerations, contact the local fuel supplier for fuel system planning and installation. Figure 1-5 lists the recommended fuel ratings and other fuel supply information for natural gas and LPG fuels.

Fuel type	Natural Gas	LPG
Fuel supply inlet	1/2 NPT	
Fuel supply pressure, kPa (in. H <sub>2</sub> O)	0.87–2.7 (3.5–11)	1.7–2.7 (7–11)
Fuel flow rate, maximum, Btu/hr.:		
8RESV/RESVL	99,200	160,800
10RESV/RESVL	179,000	222,500
12RESV/RESVL	216,000	257,500
<b>Nominal Fuel Rating, Btu/ft.<sup>3</sup></b>		
Natural gas	1000	
LPG	2500	

**Figure 1-5** Fuel Supply

Verify that the output pressure from the primary gas utility pressure regulator is as shown in Figure 1-5 and that the utility gas meter flow rate is sufficient to supply the generator set at rated load plus all other gas-consuming appliances. For LPG tanks, verify that the output pressure is as shown in Figure 1-5. See Figure 1-8 for fuel consumption. Contact the fuel supplier for flow rate information or a gas meter upgrade, if necessary.

### 1.7.2 Fuel Pipe Size

Ensure that the fuel pipe size and length meet the specifications in Figure 1-6. Measure the pipe length from the primary gas pressure regulator to the pipe connection on the generator set fuel inlet. Add 2.4 m (8 ft.) to the measured length for each 90 degree elbow. Compare the total pipe length with the chart in Figure 1-6 to find the required pipe size.

Contact local LPG provider for LPG installation information.

Minimum Gas Pipe Size Recommendation, in. NPT						
Pipe Length, m (ft.)	8RESV/RESVL		10RESV/RESVL		12RESV/RESVL	
	Natural Gas (99,200 Btu/hr.)	LPG (160,800 Btu/hr.)	Natural Gas (179,000 Btu/hr.)	LPG (222,500 Btu/hr.)	Natural Gas (216,000 Btu/hr.)	LPG (257,500 Btu/hr.)
8 (25)	3/4	3/4	3/4	3/4	3/4	3/4
15 (50)	3/4	3/4	1	3/4	1	1
30 (100)	1	3/4	1	1	1 1/4	1
46 (150)	1	1	1 1/4	1	1 1/4	1 1/4
61 (200)	1	1	1 1/4	1 1/4	1 1/4	1 1/4

**Figure 1-6** Fuel Pipe Size Recommendations

### 1.7.3 Connecting the Fuel Supply

The dimension drawing in Section 3 shows the location of the fuel inlet connection. Have the fuel supplier install rigid gas piping and a manual fuel shut-off valve. The fuel supply line should line up with the generator set fuel inlet and end about 12 inches away to allow connection with a section of flexible fuel line. Use flexible sections to prevent fuel line breakage caused by vibration.

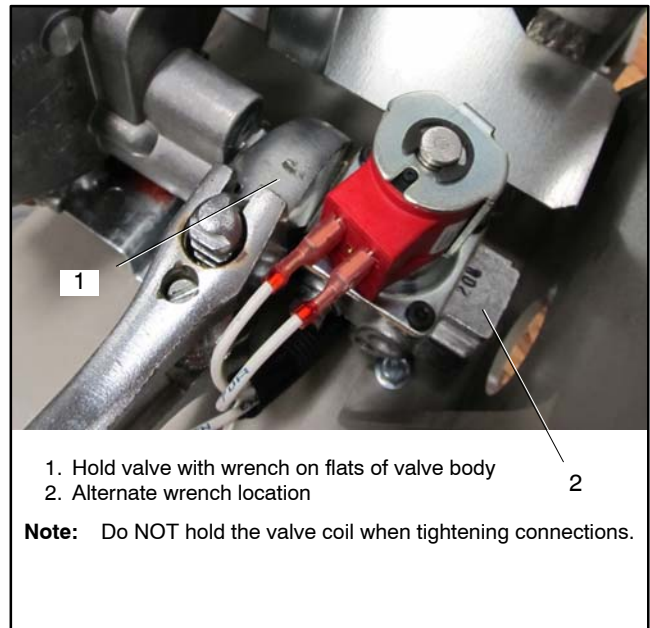
**Note:** Do not bend the flexible fuel line to make up for misalignment of the fuel supply line and the generator set fuel inlet.

Apply pipe sealant that is approved for fuel connections. Hold the fuel solenoid valve with a wrench when tightening the fuel connections.

**Note:** Do not hold the fuel solenoid valve coil when tightening the fuel connections. See Figure 1-7 for the recommended wrench locations.

Open the manual fuel valves and test all fuel connections using soapy water. If a leak is found, close the fuel valves, clean the fittings, and apply fresh sealant. Check for fuel leaks again with the generator set running.

Protect all fuel lines from machinery or equipment contact, adverse weather conditions, and environmental damage.



**Figure 1-7** Holding Fuel Valve to Tighten Fuel Connections

Fuel Type	% Load	Fuel Consumption, m <sup>3</sup> /hr. (cfh)					
		8RESV/RESVL		10RESV/RESVL		12RESV/RESVL	
		60 Hz		60 Hz		60 Hz	
Natural Gas	100%	2.8	(99)	5.1	(179)	6.1	(216)
	75%	2.2	(78)	4.1	(145)	4.5	(160)
	50%	1.8	(64)	3.4	(120)	3.6	(128)
	25%	1.5	(54)	2.7	(97)	2.8	(99)
LPG	100%	1.8	(64)	2.5	(89)	2.9	(103)
	75%	1.7	(58)	2.0	(69)	2.2	(76)
	50%	1.5	(51)	1.5	(52)	1.6	(57)
	25%	1.3	(45)	1.1	(39)	1.2	(42)
LPG conversion factors:		Nominal fuel rating:					
8.58 ft. <sup>3</sup> = 1 lb.		Natural gas: 37 MJ/m <sup>3</sup> (1000 Btu/ft. <sup>3</sup> )					
0.535 m <sup>3</sup> = 1 kg		LPG: 93 MJ/m <sup>3</sup> (2500 Btu/ft. <sup>3</sup> )					
36.39 ft. <sup>3</sup> = 1 gal.							

**Figure 1-8** Fuel Consumption

## 1.8 Fuel Conversion

The multi-fuel system allows conversion from natural gas (NG) to LPG (or vice-versa) in the field while maintaining emissions-standard compliance. A trained technician or an authorized distributor/dealer can convert the fuel system.

### **⚠ WARNING**

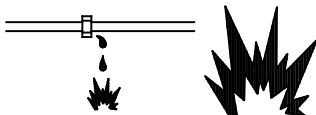


**Accidental starting.  
Can cause severe injury or death.**

Disconnect the battery cables before working on the generator set. Remove the negative (-) lead first when disconnecting the battery. Reconnect the negative (-) lead last when reconnecting the battery.

**Disabling the generator set. Accidental starting can cause severe injury or death.** Before working on the generator set or equipment connected to the set, disable the generator set as follows: (1) Press the generator set off/reset button to shut down the generator set. (2) Disconnect the power to the battery charger, if equipped. (3) Remove the battery cables, negative (-) lead first. Reconnect the negative (-) lead last when reconnecting the battery. Follow these precautions to prevent the starting of the generator set by the remote start/stop switch.

### **⚠ WARNING**



**Explosive fuel vapors.  
Can cause severe injury or death.**

Use extreme care when handling, storing, and using fuels.

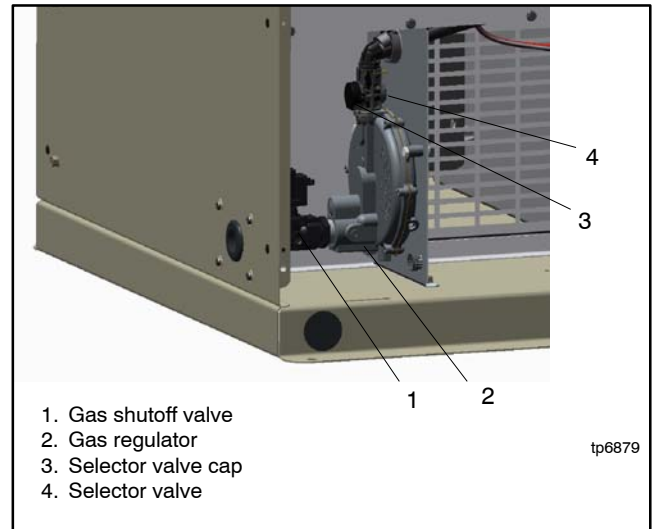
### Fuel Conversion Procedure

The fuel selector valve allows field-conversion between natural gas (NG) and LPG. The valve is factory-set to comply with applicable emission standards and to provide the best possible hot and cold starting.

**Note:** Do not adjust the factory-set screw on the selector valve. Adjusting the screw may violate federal and state laws. See Figure 1-13.

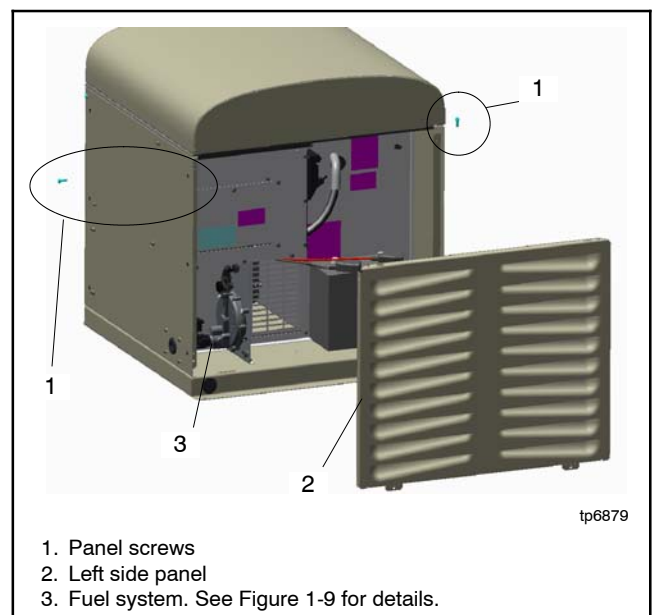
Use the following procedure to convert the fuel system. The procedure includes removing the side panel, removing the cap from the fuel selector valve, and making the fuel selection.

See Figure 1-9 for fuel system components.



**Figure 1-9** Fuel System

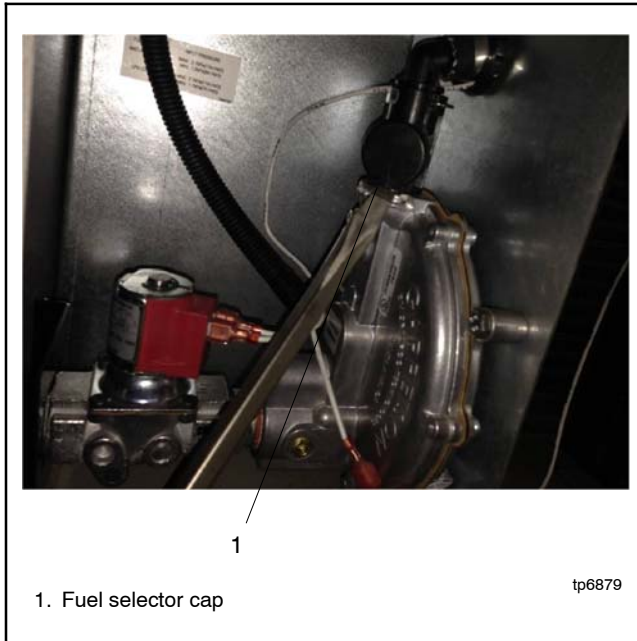
1. Press the OFF button on the generator set controller.
2. Disconnect the power to the battery charger.
3. Disconnect the generator set engine starting battery, negative (-) lead first.
4. Turn off the fuel supply.
5. Remove panel screws and remove the left side louvered panel. Figure 1-10.



**Figure 1-10** Remove Left Panel



- Remove the cap from the fuel selector valve. See Figure 1-11. Insert a flat head screwdriver under the lip of the cap and push it upwards. Keep the cap close by as it is needed to switch fuels in the next step.

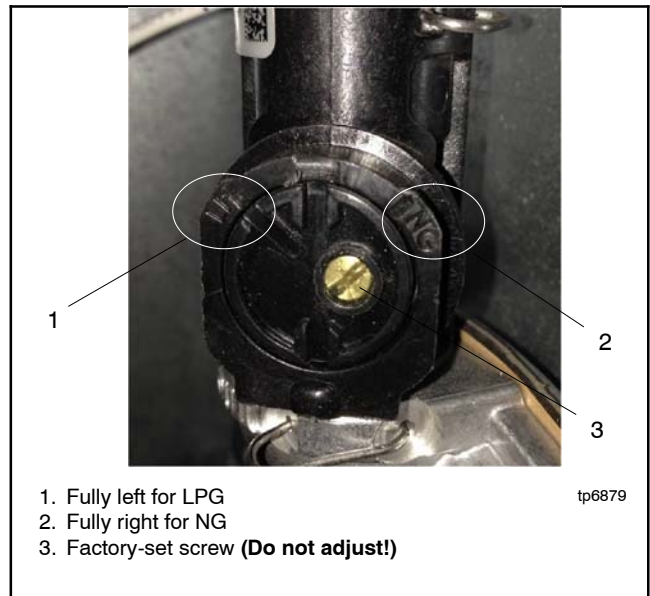


**Figure 1-11** Cap Removal

- See Figure 1-12. Use the cap in the orientation shown to turn the selector valve to NG or LP. See Figure 1-13 for valve positions.



**Figure 1-12** Fuel Selection



**Figure 1-13** Valve Positions

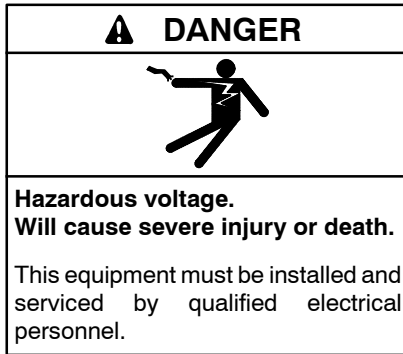
- Replace the cap.
- Connect and turn on the fuel supply (ensure that the fuel supply matches the fuel setting).
- Reconnect the generator set engine starting battery leads, negative (-) lead last.
- Reconnect power to the battery charger.
- Reassemble the left side panel.
- Start the generator set by pressing the RUN button on the generator set controller.
- Check for leaks using a gas leak detector.
- Run the generator set and check the operation.
- Press the OFF button to to shut down the generator set.

### Rating

Converting the fuel will change the generator set rating. See the generator set specification sheet for ratings with natural gas and LPG. When converting to LPG from factory settings, order a new nameplate with the updated rating and fuel information from an authorized distributor/dealer, if necessary. Provide the following information from the original nameplate:

- Model Number
- Spec Number
- Serial Number
- Fuel (original and new)
- kW
- kVA
- Amps
- Volts
- Hz

## 1.9 Electrical Connections



**Grounding electrical equipment. Hazardous voltage can cause severe injury or death.** Electrocutation is possible whenever electricity is present. Ensure you comply with all applicable codes and standards. Electrically ground the generator set, transfer switch, and related equipment and electrical circuits. Turn off the main circuit breakers of all power sources before servicing the equipment. Never contact electrical leads or appliances when standing in water or on wet ground because these conditions increase the risk of electrocution.

**Electrical backfeed to the utility. Hazardous backfeed voltage can cause severe injury or death.** Install a transfer switch in standby power installations to prevent the connection of standby and other sources of power. Electrical backfeed into a utility electrical system can cause severe injury or death to utility personnel working on power lines.

### NOTICE

**Canadian installations only.** For standby service connect the output of the generator set to a suitably rated transfer switch in accordance with Canadian Electrical Code, Part 1.

Have an authorized distributor/dealer or a licensed electrician make the following electrical connections. The electrical installation must comply with the National Electrical Code® (NEC) class 1 wire designation and all applicable local codes. Canadian installations must comply with the Canadian Electrical Code (CEC) and applicable local codes.

**AC circuit protection.** All AC circuits must include circuit breaker or fuse protection. The circuit breaker must be rated for a maximum of 125% of the rated generator set output current. The circuit breaker must open all ungrounded connectors. The generator set is equipped with a factory-installed circuit breaker.

For customer-supplied wiring, select the wire temperature rating in Figure 1-14 based upon the following criteria:

- Select row 1, 2, 3, or 4 if the circuit rating is 110 amperes or less or requires #1 AWG (42.4 mm<sup>2</sup>) or smaller conductors.
- Select row 3 or 4 if the circuit rating is greater than 110 amperes or requires #1 AWG (42.4 mm<sup>2</sup>) or larger conductors.

Row	Temp. Rating	Copper (Cu) Only	Cu/Aluminum (Al) Combinations	Al Only
1	60°C (140°F) or 75°C (167°F)	Use No. * AWG, 60°C wire or use No. * AWG, 75°C wire	Use 60°C wire, either No. * AWG Cu, or No. * AWG Al or use 75°C wire, either No. * AWG Cu or No. * AWG Al	Use 60°C wire, No. * AWG or use 75°C wire, No. * AWG
2	60°C (140°F)	Use No. * AWG, 60°C wire	Use 60°C wire, either No. * AWG Cu or No. * AWG Al	Use 60°C wire, No. * AWG
3	75°C (167°F)	Use No. *† AWG, 75°C wire	Use 75°C wire, either No. *† AWG Cu or No. *† AWG Al	Use 75°C wire, No. *† AWG
4	90°C (194°F)	Use No. *† AWG, 90°C wire	Use 90°C wire, either No. *† AWG Cu or No. *† AWG Al	Use 90°C wire, No. *† AWG

\* The wire size for 60°C (140°F) wire is not required to be included in the marking. If included, the wire size is based on ampacities for the wire given in Table 310-16 of the National Electrical Code®, in ANSI/NFPA 70, and on 115% of the maximum current that the circuit carries under rated conditions. The National Electrical Code® is a registered trademark of the National Fire Protection Association, Inc.

† Use the larger of the following conductors: the same size conductor as that used for the temperature test or one selected using the guidelines in the preceding footnote.

**Figure 1-14** Terminal Markings for Various Temperature Ratings and Conductors

### 1.9.1 Grounding

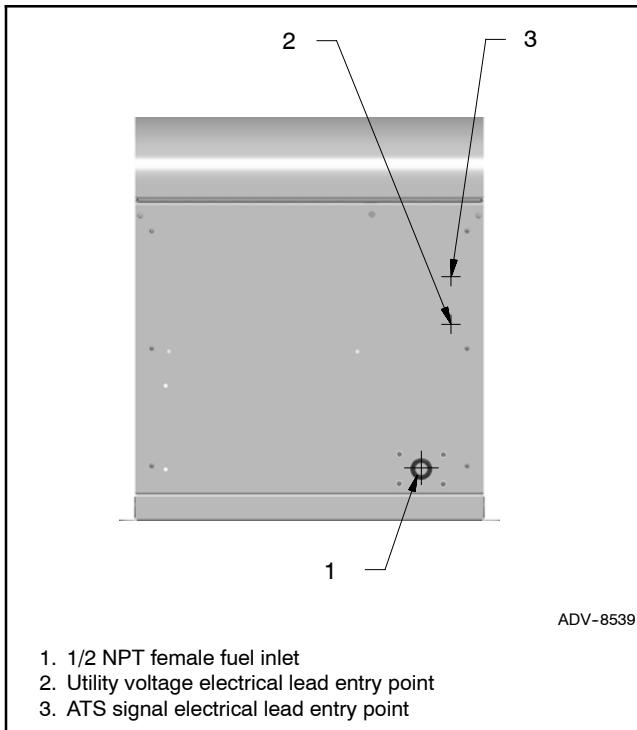
Ground the generator set. The grounding method must comply with NEC and local codes. Connect the grounding strap to the generator set ground lug, terminal GND inside the controller compartment.

Generator sets are shipped with the generator neutral bonded (connected) to the generator ground in the junction box. The requirement for having a bonded (grounded) neutral or ungrounded neutral is determined by the type of installation. At installation, the neutral can be grounded at the generator set or lifted from the ground stud and isolated if the installation requires an ungrounded neutral connection at the generator. The generator set will operate properly with the neutral either bonded to ground or isolated from ground at the generator.

Various regulations and site configurations including the National Electrical Code (NEC), local codes, and the type of transfer switch used in the application determine the grounding of the neutral at the generator. NEC Section 250 is one example that has a very good explanation of the neutral grounding requirements for generators.

### 1.9.2 Electrical Lead Entry

Drill or punch holes in the enclosure for the electrical conduit in the locations shown in Figure 1-15.

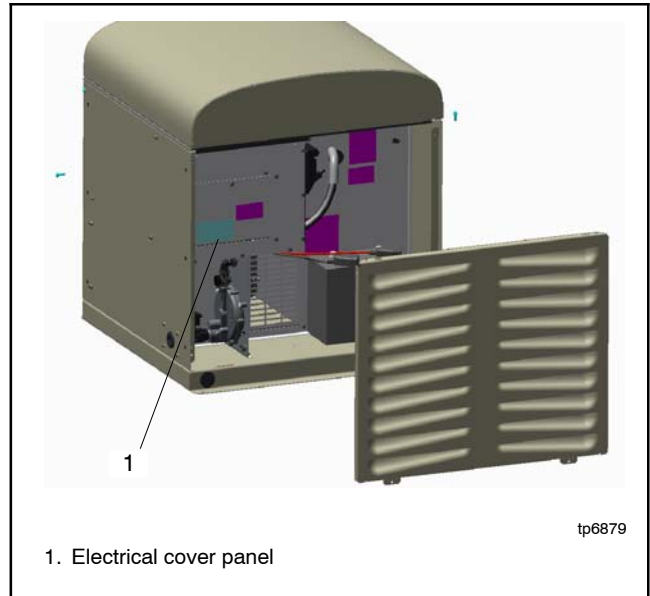


**Figure 1-15** Electrical Lead Entry Locations

### 1.9.3 Field-Connection Terminal Block

The generator set is equipped with a field-connection terminal block located in the air inlet area inside the junction box. Leads have been factory-installed from the junction box to the terminal block for easy field wiring.

See Figure 1-16 for terminal block location. Remove the cover panel for access to the field connections.



**Figure 1-16** Field-Connection Terminal Block Location

See Figure 1-17 for terminal block details. Refer to the terminal block decal for connections and cable sizes. Also see the wiring diagram in Section 3.

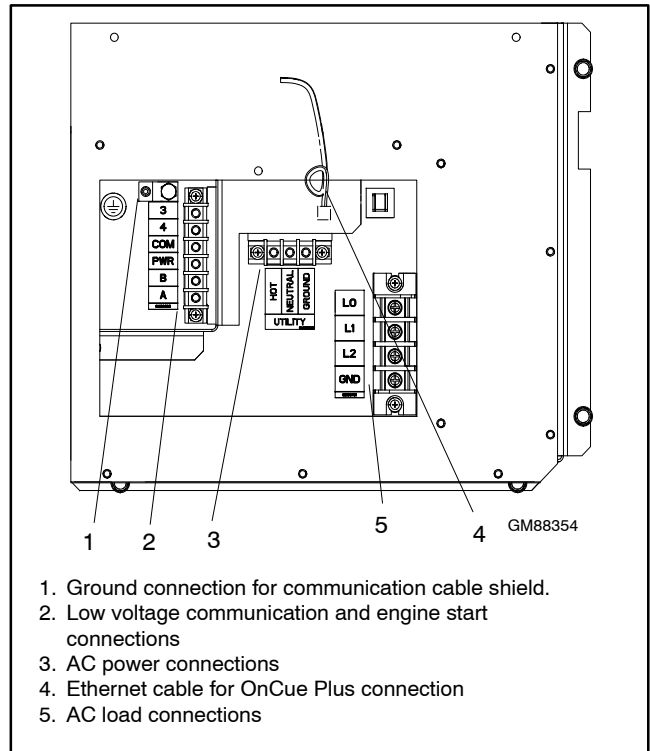
Route AC leads through flexible conduit. Ensure that the leads and conduit do not interfere with the operation of the generator set or obstruct the service areas. Route low-voltage communication leads through separate conduit.

## Procedure

1. Drill holes for the conduit fittings. See Figure 1-15 for the recommended electrical inlet locations. Feed the cables through the openings.
2. Connect the leads from the transfer switch emergency source lugs to the L1 and L2 connections on the generator set terminal block.
3. Connect the neutral (L0) and ground (GRD) leads from the ATS and the main panel to the corresponding connection points on the terminal block. See Section 1.9.1, Grounding.
4. Connect utility power leads to the terminal block connections labelled UTILITY. Connect to a circuit that is supplied by the utility source and backed up by the generator. See Section 1.9.4 for more information about the utility power requirement.
5. For connection of optional transfer switches, the programmable interface module (PIM), and/or a load control module (LCM), or the load shed kit, see Section 1.10.
6. To connect the OnCue® Plus Generator Management System to your generator, run network cable from the generator set to the customer's router or modem.

- a. Route the network cable with other low-voltage signal wiring (for example, the RBUS communication leads or engine start leads to the transfer switch), in separate conduit from the AC load leads. If the network cable is longer than 100 meters (328 ft.), use a repeater or switch.
- b. Test the internet connection for the generator by connecting a laptop to the network cable.
  - (1) Turn OFF any wireless connections to the laptop.
  - (2) Connect the network cable to the laptop. Connect the other end of the network cable to the customer's router or modem.
  - (3) Verify the Internet connection by opening your web browser and going to [www.kohlerpower.com](http://www.kohlerpower.com) or any known website.
  - (4) Disconnect the network cable from the laptop.
- c. Use an RJ45 inline coupler to connect the Ethernet cable to the cable in the customer connection box. See Figure 1-17. The inline coupler is included with the OnCue Plus kit.

7. When connections to the terminal block are complete, replace the cover plate.



**Figure 1-17** Electrical Connections

## 1.9.4 AC Power Supply

The installer must connect AC power for the battery charger (which is integral to the RDC2 controller) and the optional accessories shown in Figure 1-18. The power source must comply with state and local codes. The power to the battery charger and accessories must be backed up by the generator so that power is available at all times.



Be sure to disconnect power at the distribution panel before making the connections. Connect power leads to the utility power connection points on the terminal block. See Section 1.9.3 and the wiring diagrams in Section 3 for connection details.

Equipment	Power Requirement, Max.		
	Watts	Amps	Volts
Battery charger (standard)	50	0.4	100-250 VAC 50/60 Hz
Carburetor heater *	37	0.3	120 VAC 50/60 Hz

\* Optional accessory

**Figure 1-18** Power Requirements

## 1.10 ATS and Accessory Connections

 <b>WARNING</b>

<p><b>Hazardous voltage.</b>  <b>Backfeed to the utility system can cause property damage, severe injury, or death.</b></p> <p>If the generator set is used for standby power, install an automatic transfer switch to prevent inadvertent interconnection of standby and normal sources of supply.</p>

The following sections cover electrical connections of the automatic transfer switches and RBUS accessories, including the programmable interface module (PIM), the load control module (LCM), or the load shed kit.

### 1.10.1 Transfer Switch Connection

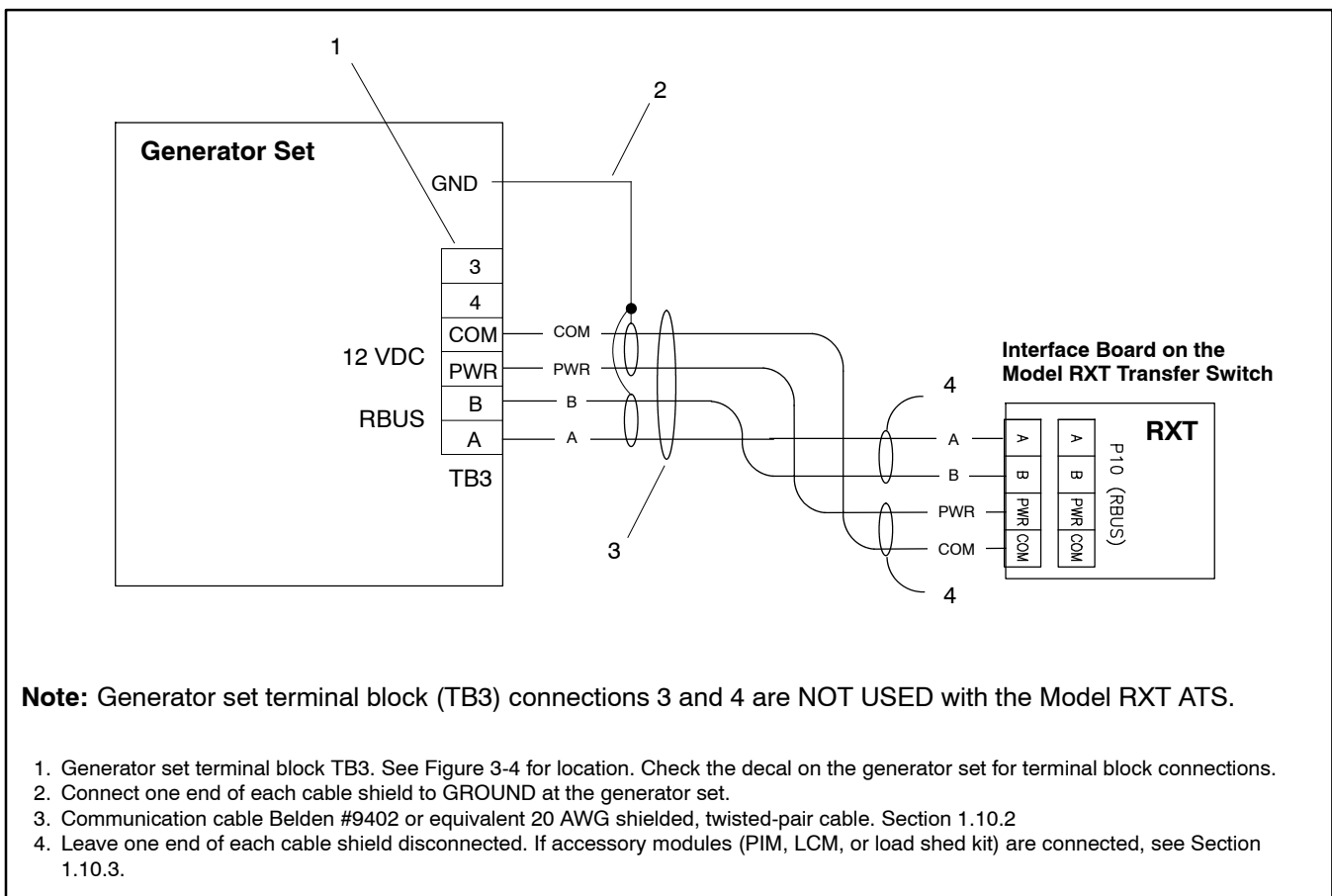
Connect the ATS or remote start/stop switch. Connect the load leads from the generator set to the Emergency source lugs on the ATS. Route low-voltage communication leads through separate conduit from the AC power and load leads. All connections must comply with applicable state and local codes.

**Note:** Do not use the Kohler® Model RRT transfer switch with the RESV or RESVL generator set.

#### Communication connections for a Kohler® Model RXT transfer switch

One Model RXT transfer switch can be connected to the generator set. See Figure 1-19. Use shielded, twisted-pair communication cable to connect P10-1 through P10-4 on the transfer switch interface module to the generator set terminal block connections A, B, PWR, and COM.

**Note:** Connections 3 and 4 on the generator set are not used with the Model RXT transfer switch.

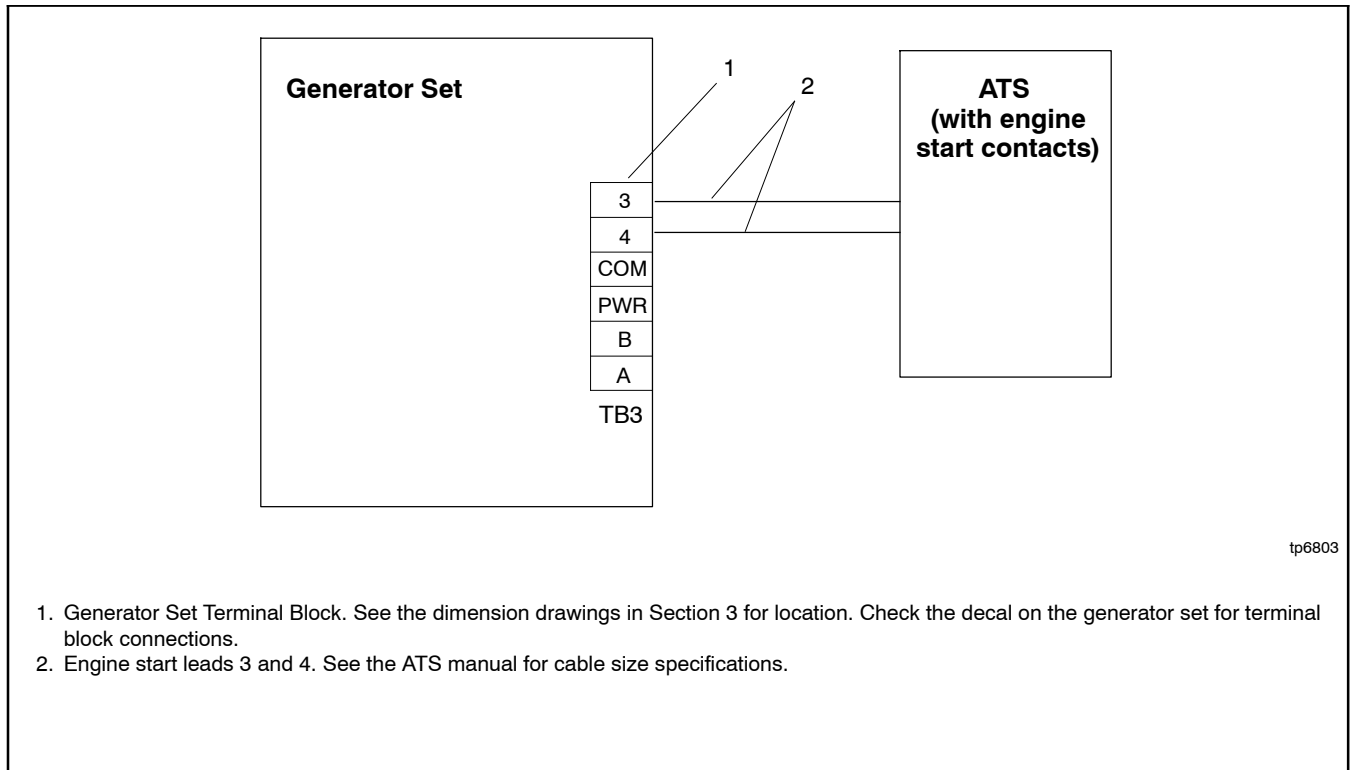


**Figure 1-19** Model RXT Transfer Switch Communication Connection to Generator Set Terminal Block

**Engine start connection for other transfer switches or a remote start/stop switch**

Connect the engine start leads from the transfer switch or remote start switch to terminals 3 and 4 on the

terminal block. See Figure 1-20. Route the engine start leads through separate conduit from the AC power and load leads.



**Figure 1-20** Engine Start Connections with Transfer Switch Models RDT or RSB

## 1.10.2 Communication Cable Specifications

### RBUS Connections A and B

For the RBUS communication connections A and B to the Model RXT transfer switch, optional PIM and/or optional LCM or load shed kit, use 20 AWG shielded, twisted-pair communication cable. Belden #9402 (two-pair) or Belden #8762 (single-pair) or equivalent cable is recommended.

For outdoor installations, including those with buried cables and/or conduit, use outdoor-rated Belden #1075A or equivalent 20 AWG shielded, twisted-pair communication cable.

### PWR and COM Connections

For the PWR and COM connections from the generator set to the RXT, PIM and/or LCM or load shed kit, use the second pair in the two-pair communication cable for short runs, or use 12–14 AWG cable for longer runs as shown in Figure 1-21.

The maximum cable length depends on the number of optional modules connected. A module can be a Model RXT transfer switch, a load control module (LCM) or a load shed kit or a programmable interface module (PIM). See Figure 1-21 for the maximum cable lengths with 1, 2, or 3 modules per cable run. Note the shield connections shown in Figure 1-23.

Cable Size for PWR and COM Connections	Indoor or Outdoor Installation	Maximum length per run, meters (ft.)		
		Number of Modules (ATS, PIM and LCM, or Load Shed Kit) per Run		
		1 Module	2 Modules	3 Modules
20 AWG Belden #9402 or equivalent, two-pair	Indoor	61 (200)	31 (100)	21 (67)
20 AWG Belden #1075A or equivalent, two-pair	Outdoor	61 (200)	31 (100)	21 (67)
14 AWG *	—	152 (500)	152 (500)	122 (400)
12 AWG *	—	152 (500)	152 (500)	152 (500)

\* Use 12 or 14 AWG cable for PWR and COM connections only. For RBUS connections A and B, use shielded, twisted pair communication cable specified in Section 1.10.2.

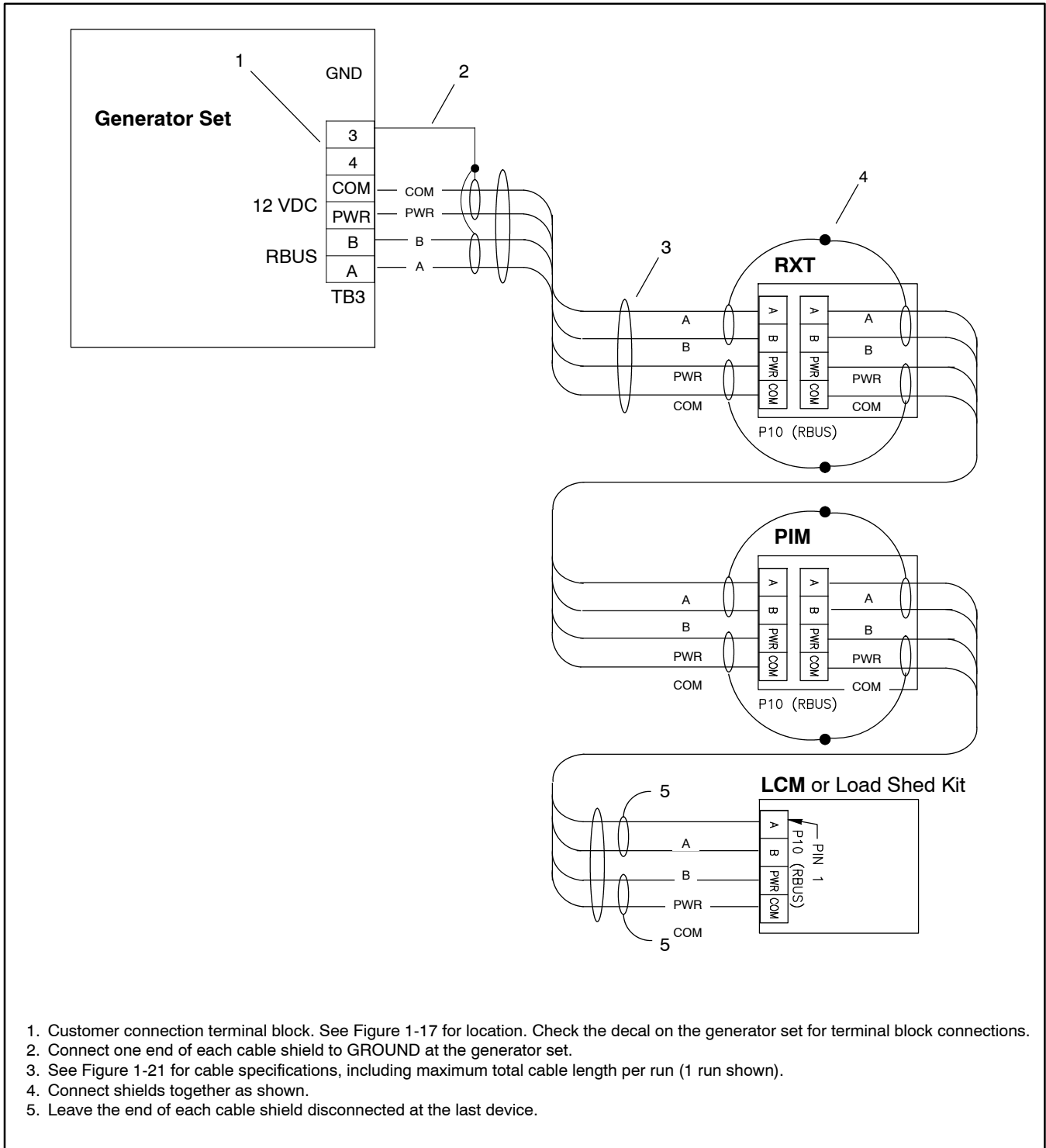
**Figure 1-21** Total Cable Lengths for PWR and COM Connections

### 1.10.3 System Connections with Accessory Modules

See Figure 1-23 through Figure 1-26 for connection options with accessory modules. Accessory modules can include one Model RXT transfer switch, one

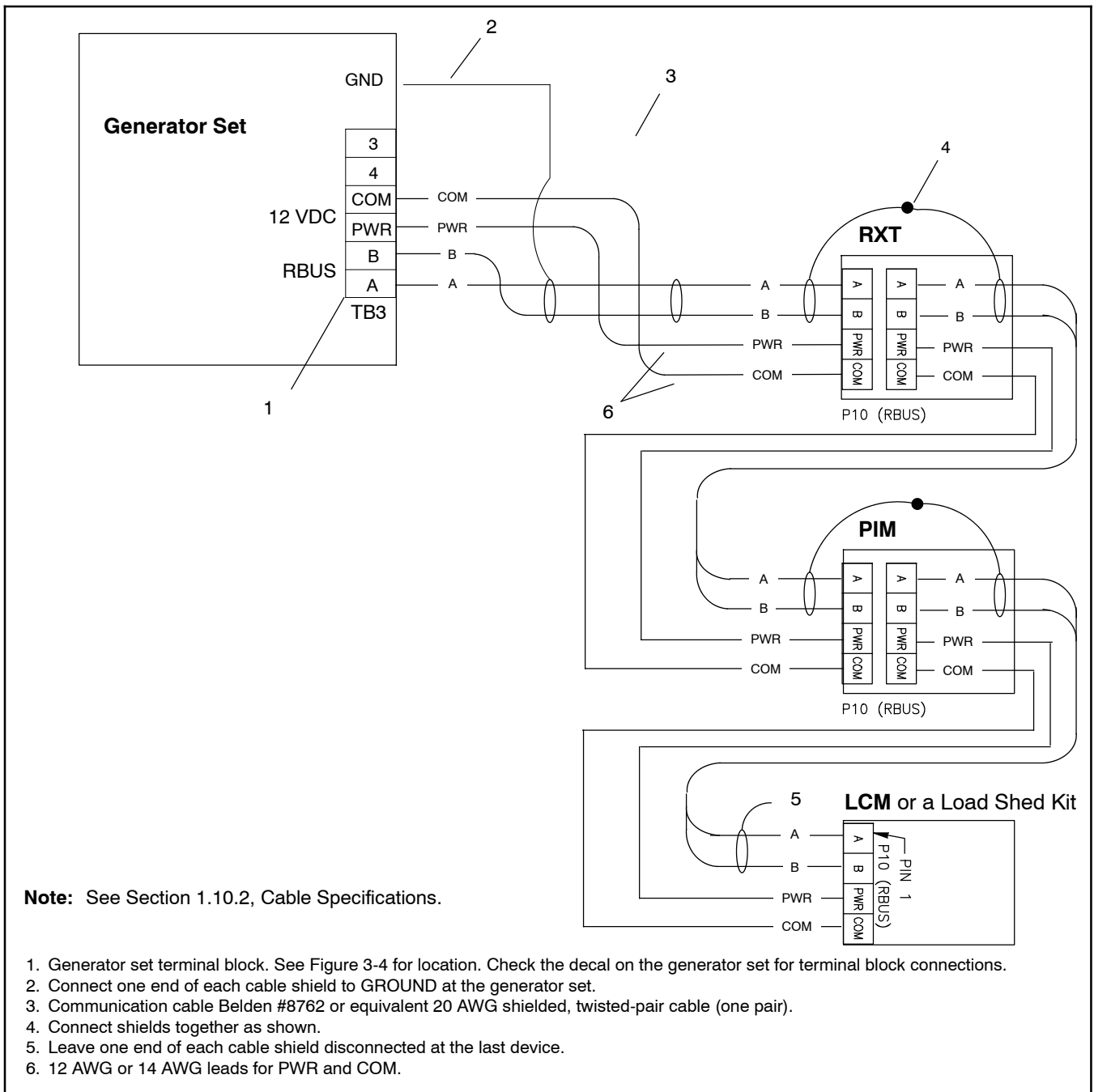
programmable interface module (PIM) and/or one load control module (LCM) or load shed kit.

See Figure 1-21 for the maximum total cable length with 1, 2, or 3 accessory modules per cable run.

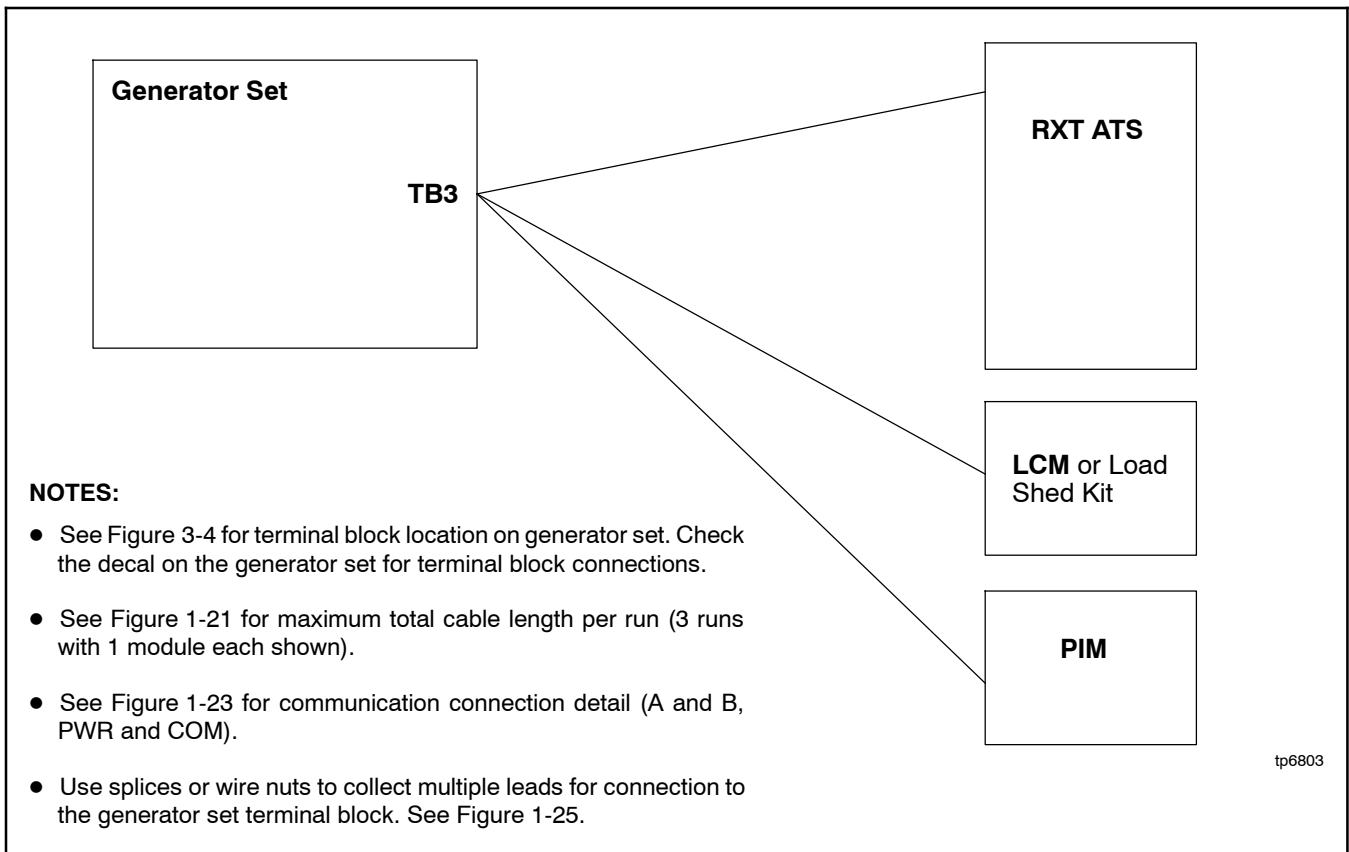


**Figure 1-22** Accessory Module Communication Connection Details

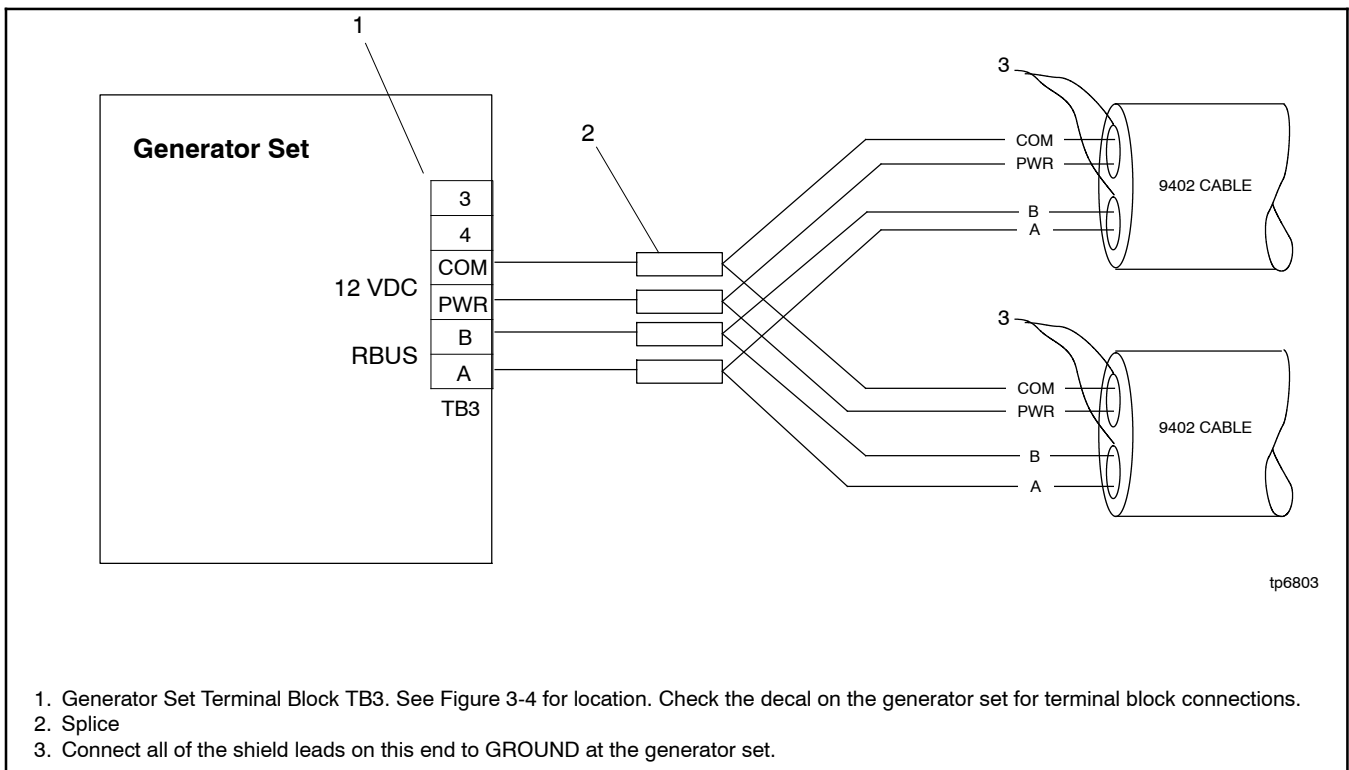




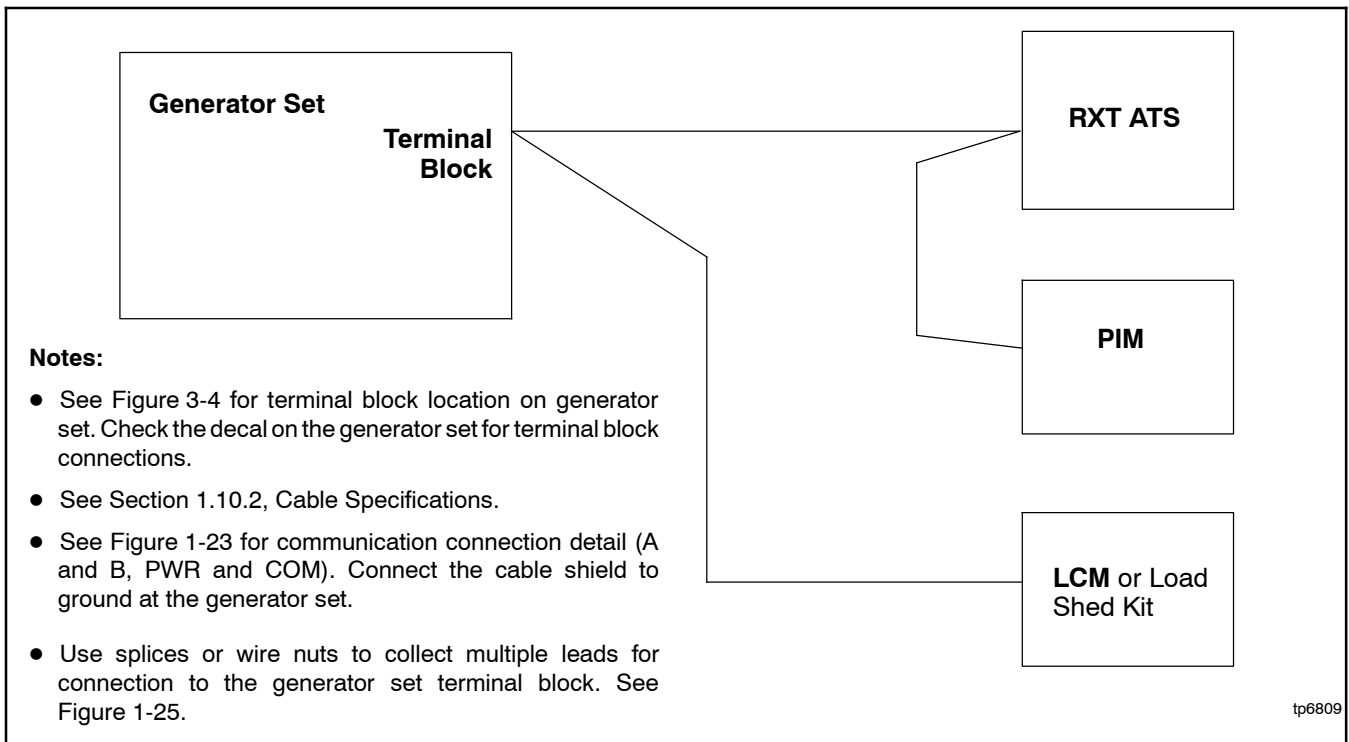
**Figure 1-23** Accessory Module Communication Connection Details



**Figure 1-24** Accessory Module Connections (three cable runs with one module each)



**Figure 1-25** Multiple Connections to the Generator Set



**Figure 1-26** Accessory Module Connections (two cable runs with one and two modules shown)

## 1.11 Battery

---

**⚠ WARNING**



**Sulfuric acid in batteries.**  
**Can cause severe injury or death.**

Wear protective goggles and clothing. Battery acid may cause blindness and burn skin.

---

**⚠ WARNING**



**Explosion.**  
**Can cause severe injury or death.**  
**Relays in the battery charger cause arcs or sparks.**

Locate the battery in a well-ventilated area. Isolate the battery charger from explosive fumes.

**Battery electrolyte is a diluted sulfuric acid. Battery acid can cause severe injury or death.** Battery acid can cause blindness and burn skin. Always wear splashproof safety goggles, rubber gloves, and boots when servicing the battery. Do not open a sealed battery or mutilate the battery case. If battery acid splashes in the eyes or on the skin, immediately flush the affected area for 15 minutes with large quantities of clean water. Seek immediate medical aid in the case of eye contact. Never add acid to a battery after placing the battery in service, as this may result in hazardous spattering of battery acid.

**Battery acid cleanup. Battery acid can cause severe injury or death.** Battery acid is electrically conductive and corrosive. Add 500 g (1 lb.) of bicarbonate of soda (baking soda) to a container with 4 L (1 gal.) of water and mix the neutralizing solution. Pour the neutralizing solution on the spilled battery acid and continue to add the neutralizing solution to the spilled battery acid until all evidence of a chemical reaction (foaming) has ceased. Flush the resulting liquid with water and dry the area.

**Battery gases. Explosion can cause severe injury or death.** Battery gases can cause an explosion. Do not smoke or permit flames or sparks to occur near a battery at any time, particularly when it is charging. Do not dispose of a battery in a fire. To prevent burns and sparks that could cause an explosion, avoid touching the battery terminals with tools or other metal objects. Remove all jewelry before servicing the equipment. Discharge static electricity from your body before touching batteries by first touching a grounded metal surface away from the battery. To avoid sparks, do not disturb the battery charger connections while the battery is charging. Always turn the battery charger off before disconnecting the battery connections. Ventilate the compartments containing batteries to prevent accumulation of explosive gases.

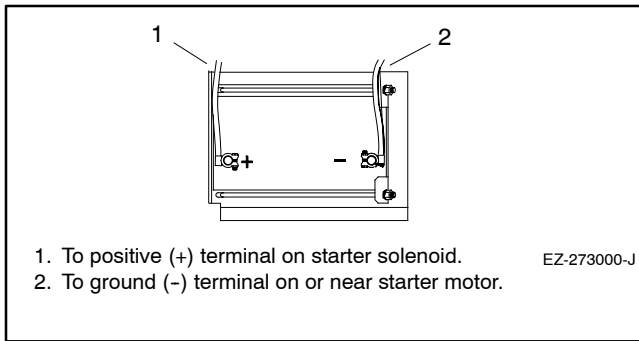
**Battery short circuits. Explosion can cause severe injury or death.** Short circuits can cause bodily injury and/or equipment damage. Disconnect the battery before generator set installation or maintenance. Remove all jewelry before servicing the equipment. Use tools with insulated handles. Remove the negative (-) lead first when disconnecting the battery. Reconnect the negative (-) lead last when reconnecting the battery. Never connect the negative (-) battery cable to the positive (+) connection terminal of the starter solenoid. Do not test the battery condition by shorting the terminals together.

**Connecting the battery and the battery charger. Hazardous voltage can cause severe injury or death.** Reconnect the battery correctly, positive to positive and negative to negative, to avoid electrical shock and damage to the battery charger and battery(ies). Have a qualified electrician install the battery(ies).

Starting batteries are usually the lead-acid type. Use a 12-volt group 51 battery with a minimum rating of 500 cold cranking amps at 0°F. The generator set uses a negative ground with a 12-volt engine electrical system. See Figure 1-27 for battery connections. Make sure that the battery is correctly connected and the terminals are tight.

**Note:** The generator set will not start and circuit board damage may occur if the battery is connected in reverse.

See the dimension drawing in Section 3 for the engine starting battery location on the air intake side of the generator set. Standard battery cables provide easy connection to the battery.



**Figure 1-27** Typical Battery Connection

Use the following procedure to install and connect the battery.

### Battery Installation Procedure

1. Ensure that the starting battery is fully charged before placing the battery in service.
2. Clean the battery posts and/or adapters if necessary.
3. Install the battery post adapters, if needed.
4. Place the battery in the housing.
5. Connect the positive (+) lead to the engine starting battery.
6. Connect the negative (-) lead to the engine starting battery.

Refer to the generator set operation manual and the battery manufacturer's instructions for battery maintenance instructions.

When power is applied to the RDC2/DC2 controller (that is, when the battery is connected), you will be prompted to set the date and time, and then to set the exerciser. See Section 1.13 and the generator set operation manual for instructions.

If the battery is disconnected for service or replacement, the exercise settings on the RDC2/DC2 controller are lost. Set the exerciser after installing and connecting the battery. See Section 1.13, Set Exerciser.

## 1.12 Prestart Installation Check

Review the entire installation section. Inspect all wiring and connections to verify that the generator set is ready for operation. Check all items in the following Prestart Checklist.

### Prestart Checklist

**Air Cleaner.** Check that a clean air cleaner element is installed to prevent unfiltered air from entering the engine. See the generator set operation manual for instructions.

**Air Inlets.** Check for clean and unobstructed air inlets.

**Battery.** Check for tight battery connections. Consult the battery manufacturer's instructions regarding battery care and maintenance.

**Enclosure.** Check that all enclosure panels and internal baffling are in place.

**Exhaust System.** Check for exhaust leaks and blockages. Check the muffler condition.

- Inspect the exhaust system components for cracks, leaks, and corrosion. Check for tight exhaust system connections.
- Check for corroded or broken metal parts and replace them as needed.
- Check that the exhaust outlet is unobstructed.

**Oil Level.** Maintain the oil level at or near, not over, the full mark on the dipstick.

**Operating Area.** Check for obstructions that could block the flow of cooling air. Keep the air intake area clean. Do not leave rags, tools, or debris on or near the generator set.

## 1.13 Set the Exerciser

Set the exerciser to automatically run the generator set on the desired day and time every week or every two weeks. See the generator set Operation Manual for detailed descriptions of the unloaded and loaded exercise operation.

**Note:** Your generator will use either the **RDC2 (RESV models)** or the **DC2 (RESVL models)** controller. Determine which controller your generator set uses and follow the directions to set that specific controller. See Figure 1-28.

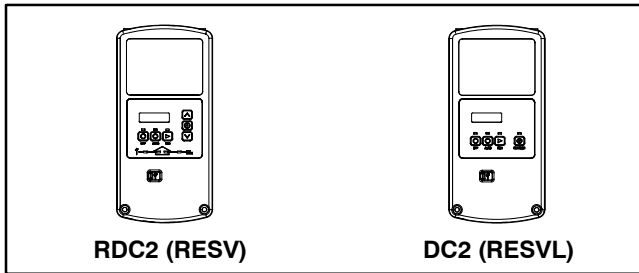


Figure 1-28 Controller Identification

### 1.13.1 RDC2 Controller

When power is applied to the RDC2 controller (when the battery or the utility power for the battery charger is connected), you will be prompted to set the date and time, and then to set the exerciser.

The first setting will flash. Press the Up and Down arrow buttons to change the setting. Press Select to save the setting and move on to the next. Repeat until the date, time, and exercise are set and the controller display shows the main menu. See the generator set Operation Manual for more detailed instructions to set the date and time and set the exerciser.

Press AUTO to place the generator set controller into automatic mode.

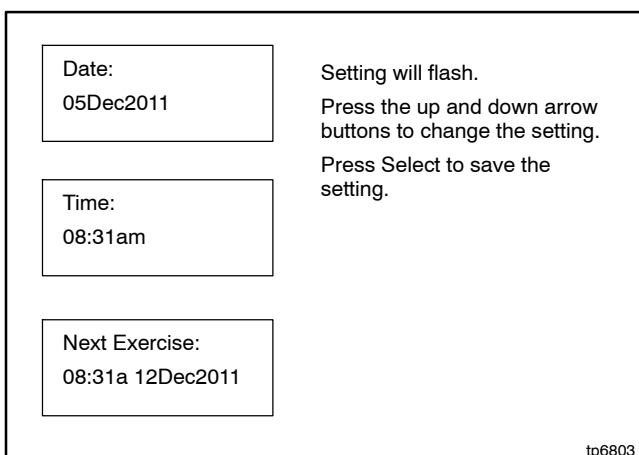


Figure 1-29 Set Time, Date, and Exercise (RDC2)

### 1.13.2 DC2 Controller

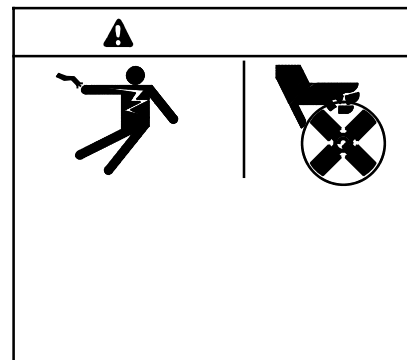
To set the exerciser on the DC2 controller, first press AUTO to place the controller into automatic (standby) mode. Then press and hold the Exercise button. The generator set will start and run a 20-minute unloaded cycle exercise. The generator set will run automatically for 20 minutes at the same time every 7 days. See the generator set Operation Manual for more information.

### 1.13.3 Loaded Exercise

In order to set a loaded exercise using the RDC2 or DC2 controller, a Kohler® Model RXT transfer switch must be connected. See the generator set operation manual for instructions to set a loaded exercise.

To set a loaded exercise on a generator set connected to a transfer switch other than a Model RXT, use the transfer switch controller to set the exercise. Refer to the transfer switch operation manual for instructions.

## 1.14 Operation Test



1. Verify that all guards and enclosure panels are in place.
2. Check the items in the Prestart Checklist in Section 1.12.
3. Press the RUN button on the generator set controller to start the generator set. Verify that the engine starts and runs.
4. Press OFF to stop the engine. Then press AUTO on the RDC2 controller.
5. Verify that the enclosure door is closed and that the panels are installed. Lock the enclosure to prevent unauthorized access.

## 1.15 OnCue Plus Generator Management System

The OnCue® Plus Generator Management System is included with the 8RESV(L), 10RESV(L), and 12RESV(L) and allows monitoring and control of your generator set from a personal computer, smart phone, or tablet. OnCue Plus can also be configured to send email or text message notifications in the event of a generator set fault. See G18-247, Quick Start Guide and TP-6928, OnCue Plus Operation Manual, for instructions.

To use OnCue Plus, you must have the following minimum requirements for connecting your generator to the Internet:

- “Always-on” Internet service for generator set connection (for example, cable, DSL, or phone line modem connected 24 hours)
- Unused Ethernet port on a switch, router, or modem
- An uninterruptible power supply (UPS) for the modem and router is recommended.
- 5E customer-supplied network cable for connection of the generator set to the customer’s Ethernet router (see installation instructions in Section 1.9.3)
- USB cable, male USB A to male mini-B, for updating the controller firmware.

For instructions on connecting the network cables to the generator set, see instructions in Section 1.9.3.

# Notes



**2.1 Introduction**

This section describes some of the accessories that are available for the generator sets. Have accessories installed by an authorized distributor/ dealer or a licensed electrician. This document does not contain installation instructions for accessories. Follow the installation instructions provided with each kit.

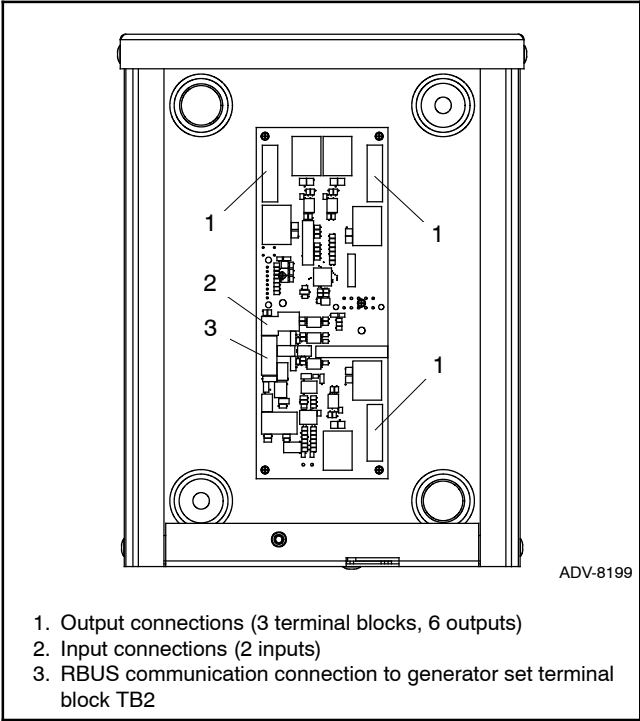
Use separate conduit for AC and DC leads to reduce the possibility of electrical interference. Verify that the leads and conduit do not interfere with the operation of the generator set or obstruct the service areas. Verify that the electrical installation complies with the National Electrical Code (NEC) and all applicable local codes. See the wiring diagrams in Section 3 for more information regarding generator set electrical connections.

**2.2 Connect Optional Programmable Interface Module (PIM)**

The optional programmable interface module (PIM) provides two programmable inputs and six dry contact outputs, four of which are programmable. See TT-1584 for PIM installation and connection instructions. Also see Section 1.10 of this manual for connection to the generator set.

The default settings for the inputs and outputs are shown in Figure 2-2. To change the input and output settings, use a personal computer running Kohler SiteTech® software. See TP-6701, SiteTech Software Operation Manual, for instructions.

Kohler OnCue® Plus can be used to actively control PIM outputs. See the OnCue Plus Operation Manual for instructions.



**Figure 2-1** Optional PIM

PIM Connection	Factory Default Setting
Input 1	None
Input 2	None
Output 1 (Relay 1)	Run
Output 2 (Relay 2)	Common Fault
Output 3 (Relay 3)	Low Battery Voltage (Programmable)
Output 4 (Relay 4)	Not in Auto (Programmable)
Output 5 (Relay 5)	Cooldown (Programmable)
Output 6 (Relay 6)	Normal Source Failure (Programmable)

**Figure 2-2** PIM Inputs and Outputs

## 2.3 Load Control Module (LCM)

The optional Load Control Module (LCM) is available for single-phase generator sets only. The LCM provides an automatic load management system to comply with Section 702.5 of NEC 2008. The installer is responsible for ensuring that the power system installation complies with all applicable state and local codes.

With the Load Control Module (LCM), less critical appliances can be powered by the generator set when the more important appliances are not running, allowing the use of a smaller generator set than would be needed to run all of the building's electrical equipment at the same time.

The LCM receives commands from the RDC2 or DC2 generator controller and energizes or de-energizes the appropriate load relays to add or shed non-critical loads according to their priority.

**Note:** Connect only non-essential loads to the load control module.

The load control module automatically manages up to six residential loads:

- Four power relays are provided for management of non-essential secondary loads. 120 VAC power must be provided for operation of the power relays.
- Two relays are available to control two independent air conditioner loads.

The LCM is available with either a prewired harness for load relay connection, or a terminal block. The prewired harness requires installation of the LCM within 0.6 meters (2 feet) of the distribution panel. The load control module with the optional wire harness is shown in Figure 2-3. If the harness is not used, connect to the terminal blocks inside the LCM enclosure. Figure 2-4 shows the load control module without the optional harness.

Refer to TT-1574, provided with the LCM, for installation and connection instructions.



**Figure 2-3** Load Control Module (shown with optional wire harness)



**Figure 2-4** Load Control Module (cover removed to show field-connection terminal blocks)

## 2.4 Load Shed Kit

A load shed kit can be used on single-phase systems that include a Model RDT or RXT transfer switch. The load shed kit mounts inside the Model RDT or Model RXT transfer switch enclosure. Figure 3 shows the load shed assembly.

The optional load shed kit provides an automatic load management system to comply with Section 702.5 of NEC 2008. The installer is responsible for ensuring that the power system installation complies with all applicable state and local codes.

**Note:** Do not install both a load shed kit and a load control module (LCM) on the same system.

The load shed kit provides the same load shed and add functions as the load control module (LCM). See Section 2.3.

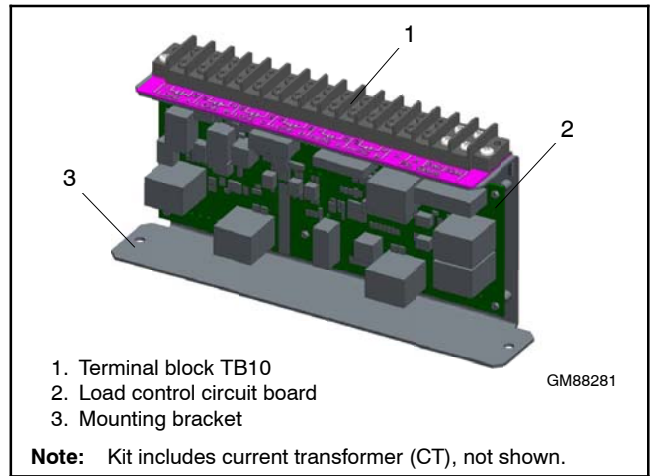
**Note:** Connect only non-essential loads to the load shed kit.

The load shed kit automatically manages up to six residential loads:

- Up to four customer-supplied power relays can be connected through normally open relay contacts on the circuit board. See TT-1609 for relay coil voltage specifications.
- Two relays are included to control two independent heating, ventilation, and air conditioning (HVAC) loads.



An adequate electrical supply is required for operation of the customer-supplied power relays connected to the load shed kit. Check the electrical requirements of the customer-provided equipment prior to installation to determine the wire size and circuit protection required. Verify that customer-provided equipment complies with applicable local and national electrical codes.

See TT-1609, provided with the kit, for detailed installation and connection instructions.



**Figure 3** Load Shed Assembly GM88281-1

## 2.5 Carburetor Heater

 <b>WARNING</b>

<p><b>Hot engine and exhaust system. Can cause severe injury or death.</b></p> <p>Do not work on the generator set until it cools.</p>

**Servicing the engine heater. Hot parts can cause minor personal injury or property damage.** Install the heater before connecting it to power. Operating the heater before installation can cause burns and component damage. Disconnect power to the heater and allow it to cool before servicing the heater or nearby parts.

An optional carburetor heater is recommended for improved cold starting in locations where the ambient temperature drops below 0°C (32°F). The carburetor heater prevents condensation and carburetor icing. The heater turns on when the temperature at the thermostat falls below approximately 4°C (40°F) and turns off when the temperature rises above approximately 16°C (60°F). The carburetor heater is shown in Figure 2-6.

To install the carburetor heater, follow the instructions provided with the kit. Figure 2-7 shows the installed carburetor heater kit.

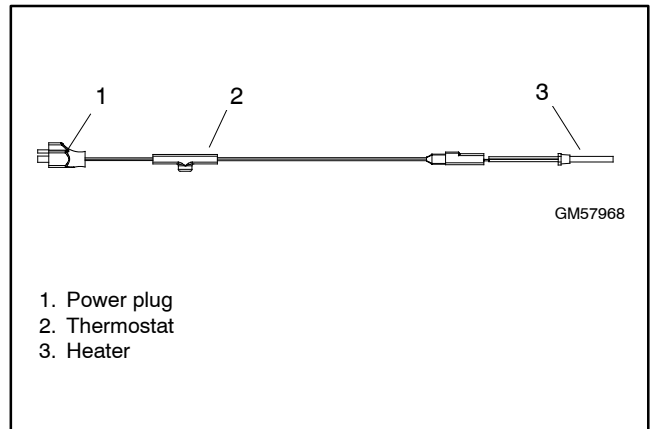
Verify that AC power is connected to the generator set as described in Section 1.9. The circuit must be backed up by the generator set to provide power at all times.

The heater thermostat is installed in the cord. Figure 2-6 shows the location of the thermostat on the power cord. The heater power cord and thermostat are located in the generator set housing air intake area/ battery compartment.

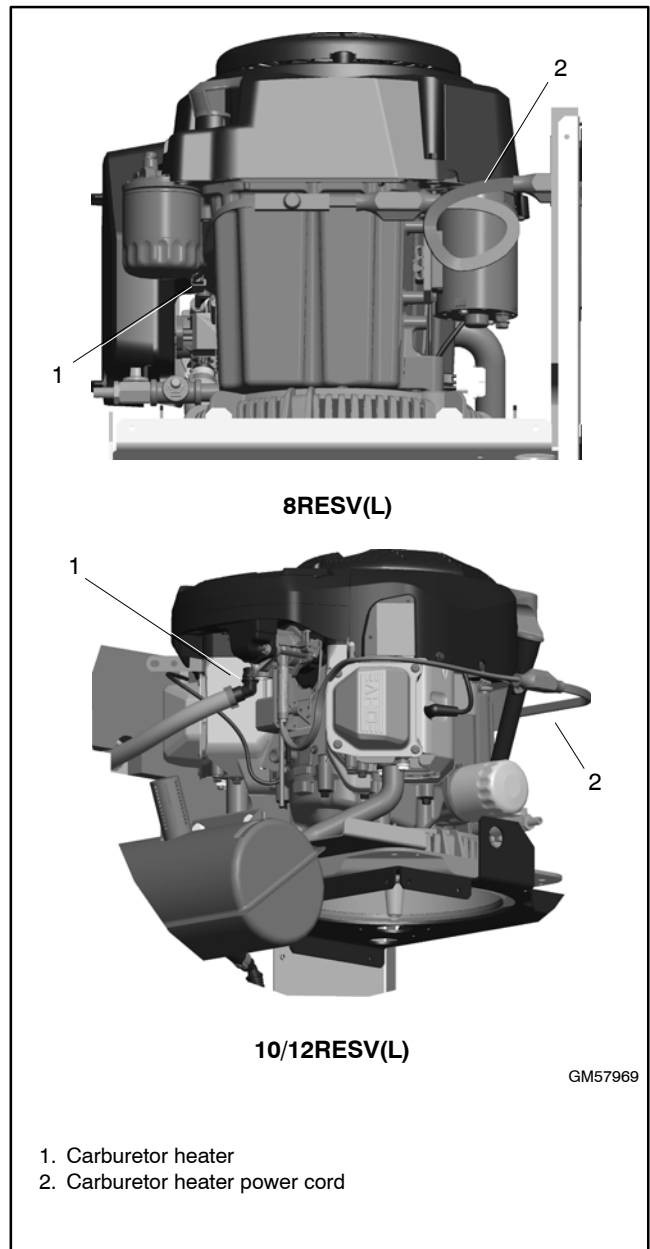
The heater requires a continuous source of power. Plug the carburetor heater into the 120 VAC receptacle provided.

Kit Number	120 Volt Kits
Voltage	120 VAC 50/60 Hz
Thermostat ON	4 ± 4°C (40 ± 7°F)
Thermostat OFF	16 ± 3°C (60 ± 5°F)

**Figure 2-5** Carburetor Heater Specifications



**Figure 2-6** Carburetor Heater



**Figure 2-7** Carburetor Heater Location

## Section 3 Drawings and Diagrams

---

Figure 3-1 lists the wiring diagram numbers and page numbers.

<b>Dimension Drawing</b>	<b>Drawing Number</b>	<b>Page</b>
Dimension Drawing	ADV-8539, Sheet 1	38
	ADV-8539, Sheet 2	39
	ADV-8539, Sheet 3	40
<b>Wiring Diagram Description</b>	<b>Drawing Number</b>	<b>Page</b>
Schematic Diagram	ADV-8552	41
Point-to-Point Wiring Diagram	GM89012	42

**Figure 3-1** Wiring Diagrams and Schematics

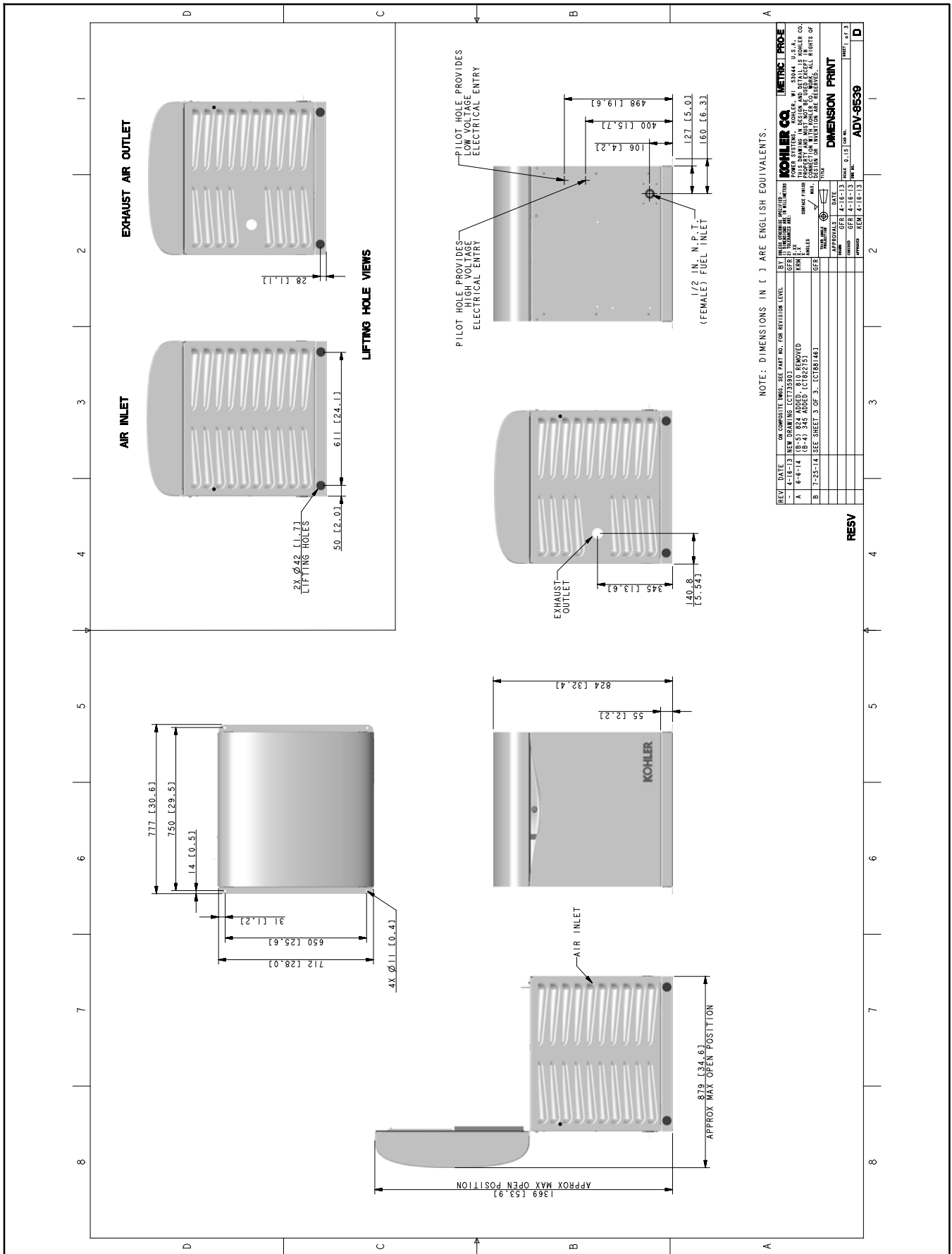


Figure 3-2 Dimension Drawing ADV-8539, Sheet 1

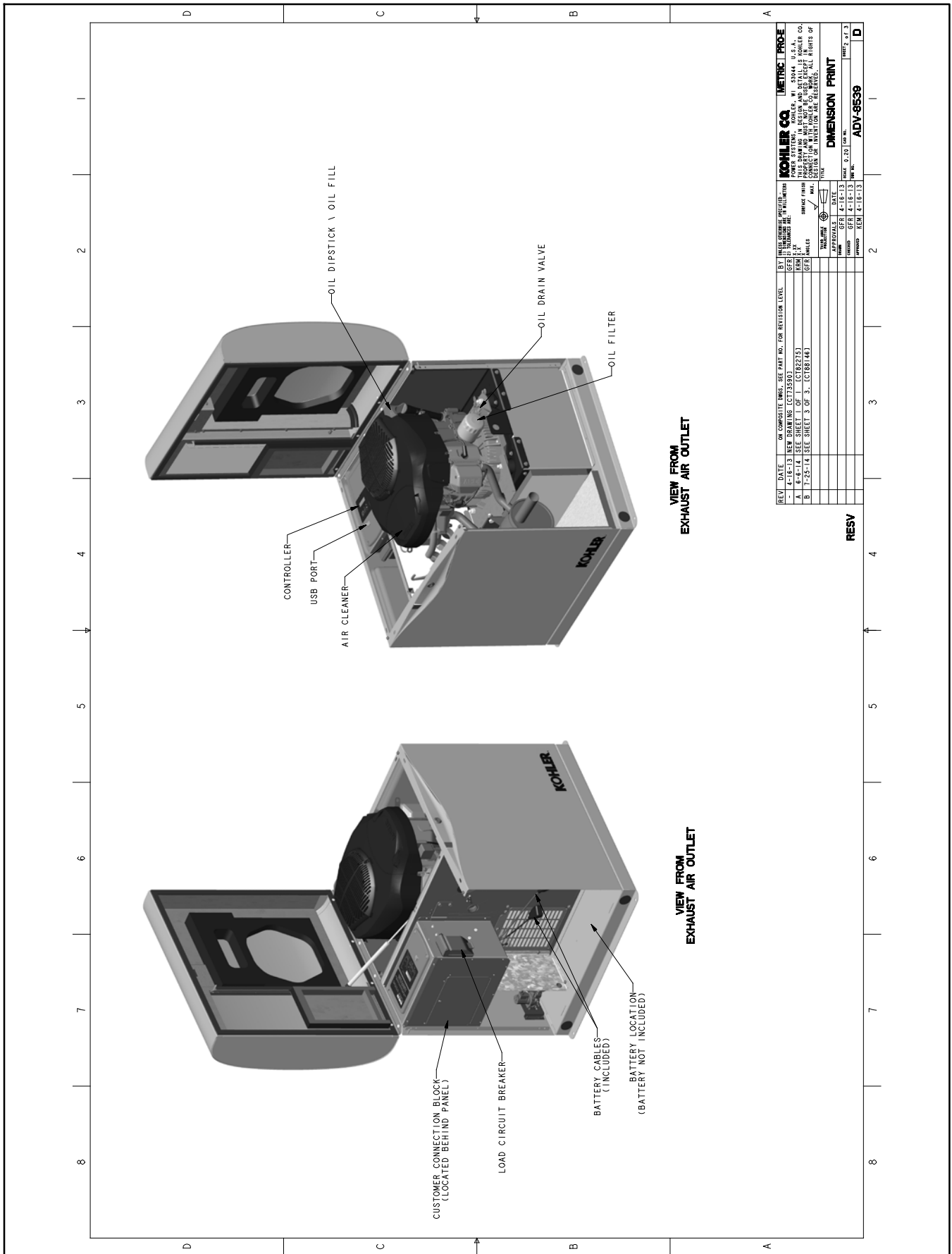
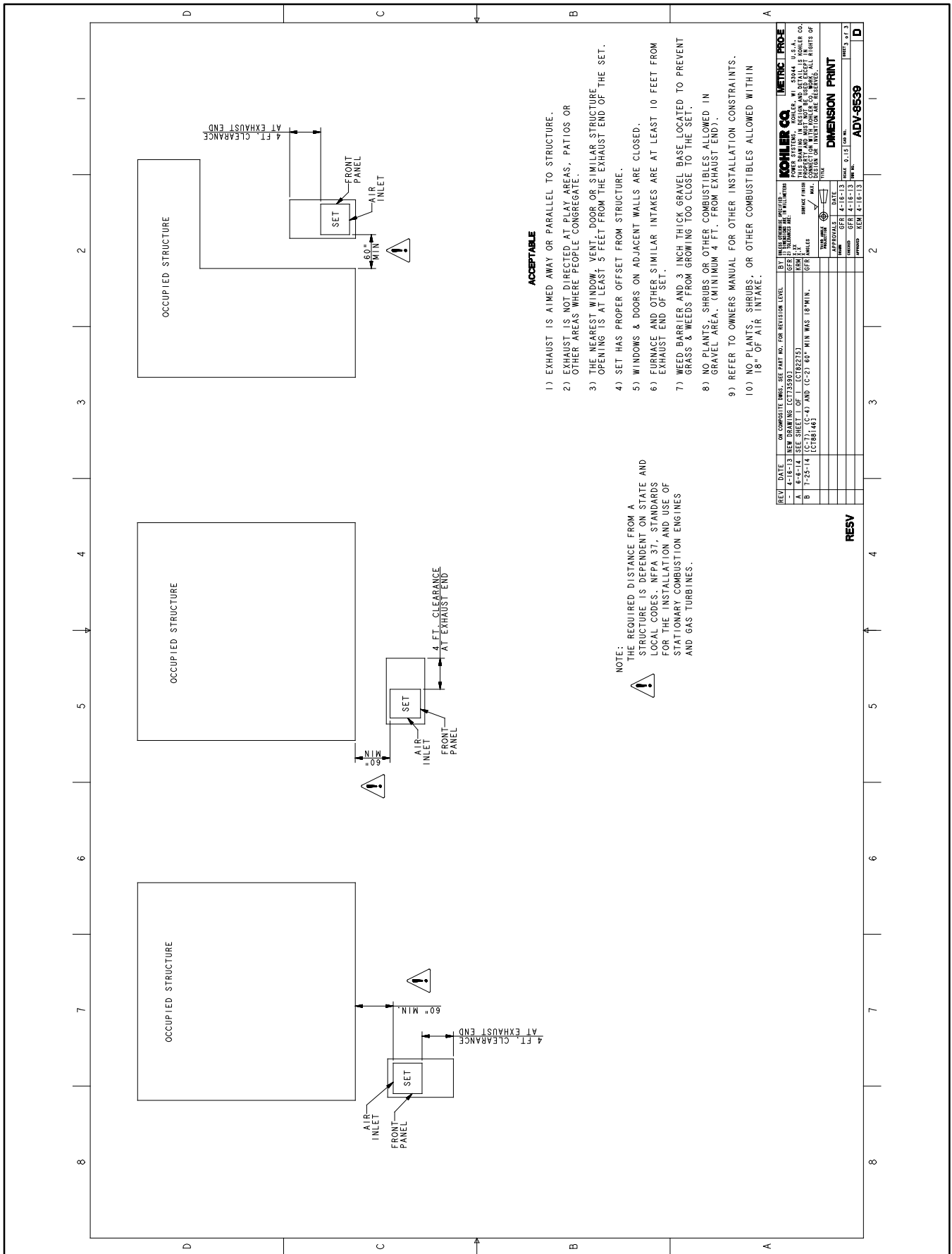


Figure 3-3 Dimension Drawing ADV-8539, Sheet 2



**Figure 3-4** Dimension Drawing ADV-8539, Sheet 3



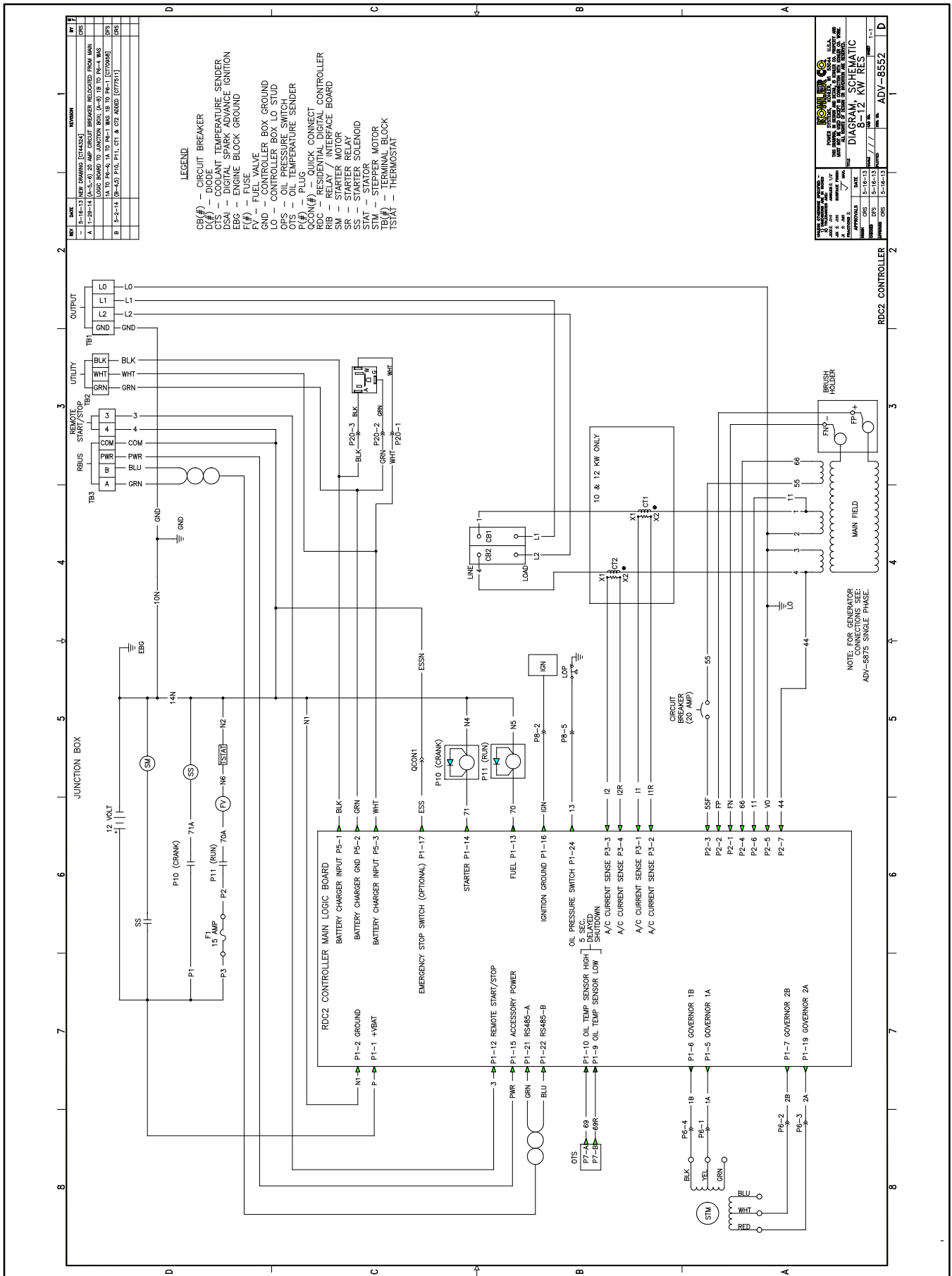


Figure 3-5 Schematic Diagram, ADV-8552



# Appendix A Abbreviations

The following list contains abbreviations that may appear in this publication.

A, amp	ampere	cfm	cubic feet per minute	exh.	exhaust
ABDC	after bottom dead center	CG	center of gravity	ext.	external
AC	alternating current	CID	cubic inch displacement	F	Fahrenheit, female
A/D	analog to digital	CL	centerline	FHM	flat head machine (screw)
ADC	advanced digital control; analog to digital converter	cm	centimeter	fl. oz.	fluid ounce
adj.	adjust, adjustment	CMOS	complementary metal oxide substrate (semiconductor)	flex.	flexible
ADV	advertising dimensional drawing	com	communications (port)	freq.	frequency
Ah	amp-hour	coml	commercial	FS	full scale
AHWT	anticipatory high water temperature	Coml/Rec	Commercial/Recreational connection	ft.	foot, feet
AISI	American Iron and Steel Institute	conn.	connection	ft. lb.	foot pounds (torque)
ALOP	anticipatory low oil pressure	cont.	continued	ft./min.	feet per minute
alt.	alternator	CPVC	chlorinated polyvinyl chloride	ftp	file transfer protocol
Al	aluminum	crit.	critical	g	gram
ANSI	American National Standards Institute (formerly American Standards Association, ASA)	CSA	Canadian Standards Association	ga.	gauge (meters, wire size)
AO	anticipatory only	CT	current transformer	gal.	gallon
APDC	Air Pollution Control District	Cu	copper	gen.	generator
API	American Petroleum Institute	cUL	Canadian Underwriter's Laboratories	genset	generator set
approx.	approximate, approximately	CUL	Canadian Underwriter's Laboratories	GFI	ground fault interrupter
APU	Auxiliary Power Unit	cu. in.	cubic inch	GND, ⊕	ground
AQMD	Air Quality Management District	cw.	clockwise	gov.	governor
AR	as required, as requested	CWC	city water-cooled	gph	gallons per hour
AS	as supplied, as stated, as suggested	cyl.	cylinder	gpm	gallons per minute
ASE	American Society of Engineers	D/A	digital to analog	gr.	grade, gross
ASME	American Society of Mechanical Engineers	DAC	digital to analog converter	GRD	equipment ground
assy.	assembly	dB	decibel	gr. wt.	gross weight
ASTM	American Society for Testing Materials	dB(A)	decibel (A weighted)	H x W x D	height by width by depth
ATDC	after top dead center	DC	direct current	HC	hex cap
ATS	automatic transfer switch	DCR	direct current resistance	HCHT	high cylinder head temperature
auto.	automatic	deg., °	degree	HD	heavy duty
aux.	auxiliary	dept.	department	HET	high exhaust temp., high engine temp.
avg.	average	dia.	diameter	hex	hexagon
AVR	automatic voltage regulator	DI/EO	dual inlet/end outlet	Hg	mercury (element)
AWG	American Wire Gauge	DIN	Deutsches Institut fur Normung e. V. (also Deutsche Industrie Normenausschuss)	HH	hex head
AWM	appliance wiring material	DIP	dual inline package	HHC	hex head cap
bat.	battery	DPDT	double-pole, double-throw	HP	horsepower
BBDC	before bottom dead center	DPST	double-pole, single-throw	hr.	hour
BC	battery charger, battery charging	DS	disconnect switch	HS	heat shrink
BCA	battery charging alternator	DVR	digital voltage regulator	hsg.	housing
BCI	Battery Council International	E <sup>2</sup> PROM, EEPROM	electrically-erasable programmable read-only memory	HVAC	heating, ventilation, and air conditioning
BDC	before dead center	E, emer.	emergency (power source)	HWT	high water temperature
BHP	brake horsepower	ECM	electronic control module, engine control module	Hz	hertz (cycles per second)
blk.	black (paint color), block (engine)	EDI	electronic data interchange	IBC	International Building Code
blk. htr.	block heater	EFR	emergency frequency relay	IC	integrated circuit
BMEP	brake mean effective pressure	e.g.	for example ( <i>exempli gratia</i> )	ID	inside diameter, identification
bps	bits per second	EG	electronic governor	IEC	International Electrotechnical Commission
br.	brass	EGSA	Electrical Generating Systems Association	IEEE	Institute of Electrical and Electronics Engineers
BTDC	before top dead center	EIA	Electronic Industries Association	IMS	improved motor starting
Btu	British thermal unit	EI/EO	end inlet/end outlet	in.	inch
Btu/min.	British thermal units per minute	EMI	electromagnetic interference	in. H <sub>2</sub> O	inches of water
C	Celsius, centigrade	emiss.	emission	in. Hg	inches of mercury
cal.	calorie	eng.	engine	in. lb.	inch pounds
CAN	controller area network	EPA	Environmental Protection Agency	Inc.	incorporated
CARB	California Air Resources Board	EPS	emergency power system	ind.	industrial
CAT5	Category 5 (network cable)	ER	emergency relay	int.	internal
CB	circuit breaker	ES	engineering special, engineered special	int./ext.	internal/external
CC	crank cycle	ESD	electrostatic discharge	I/O	input/output
cc	cubic centimeter	est.	estimated	IP	internet protocol
CCA	cold cranking amps	E-Stop	emergency stop	ISO	International Organization for Standardization
ccw.	counterclockwise	etc.	et cetera (and so forth)	J	joule
CEC	Canadian Electrical Code			JIS	Japanese Industry Standard
cert.	certificate, certification, certified			k	kilo (1000)
cfh	cubic feet per hour			K	kelvin
				kA	kiloampere
				KB	kilobyte (2 <sup>10</sup> bytes)
				KBus	Kohler communication protocol
				kg	kilogram

kg/cm <sup>2</sup>	kilograms per square centimeter	NC	normally closed	RTU	remote terminal unit
kgm	kilogram-meter	NEC	National Electrical Code	RTV	room temperature vulcanization
kg/m <sup>3</sup>	kilograms per cubic meter	NEMA	National Electrical Manufacturers Association	RW	read/write
kHz	kilohertz	NFPA	National Fire Protection Association	SAE	Society of Automotive Engineers
kJ	kilojoule	Nm	newton meter	scfm	standard cubic feet per minute
km	kilometer	NO	normally open	SCR	silicon controlled rectifier
kOhm, kΩ	kilo-ohm	no., nos.	number, numbers	s, sec.	second
kPa	kilopascal	NPS	National Pipe, Straight	SI	<i>Systeme international d'unites</i> , International System of Units
kph	kilometers per hour	NPSC	National Pipe, Straight-coupling	SI/EO	side in/end out
kV	kilovolt	NPT	National Standard taper pipe thread per general use	sil.	silencer
kVA	kilovolt ampere	NPTF	National Pipe, Taper-Fine	SMTP	simple mail transfer protocol
kVAR	kilovolt ampere reactive	NR	not required, normal relay	SN	serial number
kW	kilowatt	ns	nanosecond	SNMP	simple network management protocol
kWh	kilowatt-hour	OC	overcrank	SPDT	single-pole, double-throw
kWm	kilowatt mechanical	OD	outside diameter	SPST	single-pole, single-throw
kWth	kilowatt-thermal	OEM	original equipment manufacturer	spec	specification
L	liter	OF	overfrequency	specs	specification(s)
LAN	local area network	opt.	option, optional	sq.	square
L x W x H	length by width by height	OS	oversize, overspeed	sq. cm	square centimeter
lb.	pound, pounds	OSHA	Occupational Safety and Health Administration	sq. in.	square inch
lbm/ft <sup>3</sup>	pounds mass per cubic feet	OV	overvoltage	SMS	short message service
LCB	line circuit breaker	oz.	ounce	SS	stainless steel
LCD	liquid crystal display	p., pp.	page, pages	std.	standard
LED	light emitting diode	PC	personal computer	stl.	steel
Lph	liters per hour	PCB	printed circuit board	tach.	tachometer
Lpm	liters per minute	pF	picofarad	TB	terminal block
LOP	low oil pressure	PF	power factor	TCP	transmission control protocol
LP	liquefied petroleum	ph., ∅	phase	TD	time delay
LPG	liquefied petroleum gas	PHC	Phillips® head CrimpTite® (screw)	TDC	top dead center
LS	left side	PHH	Phillips® hex head (screw)	TDEC	time delay engine cooldown
L <sub>wa</sub>	sound power level, A weighted	PHM	pan head machine (screw)	TDEN	time delay emergency to normal
LWL	low water level	PLC	programmable logic control	TDES	time delay engine start
LWT	low water temperature	PLC	programmable logic control	TDNE	time delay normal to emergency
m	meter, milli (1/1000)	PMG	permanent magnet generator	TDOE	time delay off to emergency
M	mega (10 <sup>6</sup> when used with SI units), male	pot	potentiometer, potential	TDON	time delay off to normal
m <sup>3</sup>	cubic meter	ppm	parts per million	temp.	temperature
m <sup>3</sup> /hr.	cubic meters per hour	PROM	programmable read-only memory	term.	terminal
m <sup>3</sup> /min.	cubic meters per minute	psi	pounds per square inch	THD	total harmonic distortion
mA	milliampere	psig	pounds per square inch gauge	TIF	telephone influence factor
man.	manual	pt.	pint	tol.	tolerance
max.	maximum	PTC	positive temperature coefficient	turbo.	turbocharger
MB	megabyte (2 <sup>20</sup> bytes)	PTO	power takeoff	typ.	typical (same in multiple locations)
MCCB	molded-case circuit breaker	PVC	polyvinyl chloride	UF	underfrequency
MCM	one thousand circular mils	qt.	quart, quarts	UHF	ultrahigh frequency
megggar	megohmmeter	qty.	quantity	UIF	user interface
MHz	megahertz	R	replacement (emergency)	UL	Underwriter's Laboratories, Inc.
mi.	mile	rad.	radiator, radius	UNC	unified coarse thread (was NC)
mil	one one-thousandth of an inch	RAM	random access memory	UNF	unified fine thread (was NF)
min.	minimum, minute	RBUS	RS-485 proprietary communications	univ.	universal
misc.	miscellaneous	RDO	relay driver output	URL	uniform resource locator (web address)
MJ	megajoule	ref.	reference	US	undersize, underspeed
mJ	millijoule	rem.	remote	UV	ultraviolet, undervoltage
mm	millimeter	Res/Coml	Residential/Commercial	V	volt
mOhm, mΩ	milliohm	RFI	radio frequency interference	VAC	volts alternating current
MOhm, MΩ	megohm	RH	round head	VAR	voltampere reactive
MOV	metal oxide varistor	RHM	round head machine (screw)	VDC	volts direct current
MPa	megapascal	rly.	relay	VFD	vacuum fluorescent display
mpg	miles per gallon	rms	root mean square	VGA	video graphics adapter
mph	miles per hour	rnd.	round	VHF	very high frequency
MS	military standard	RO	read only	W	watt
ms	millisecond	ROM	read only memory	WCR	withstand and closing rating
m/sec.	meters per second	rot.	rotate, rotating	w/	with
mtg.	mounting	rpm	revolutions per minute	WO	write only
MTU	Motoren-und Turbinen-Union	RS	right side	w/o	without
MW	megawatt	RTDs	Resistance Temperature Detectors	wt.	weight
mW	milliwatt			xfmr	transformer
μF	microfarad				
N, norm.	normal (power source)				
NA	not available, not applicable				
nat. gas	natural gas				
NBS	National Bureau of Standards				







# **KOHLER**<sup>®</sup> Power Systems

KOHLER CO. Kohler, Wisconsin 53044  
Phone 920-457-4441, Fax 920-459-1646

Kohler Power Systems  
Asia Pacific Headquarters  
7 Jurong Pier Road  
Singapore 619159  
Phone (65) 6264-6422, Fax (65) 6264-6455

**For the nearest KOHLER authorized  
installation, service, and sales dealer in  
the US and Canada:  
Call 1-800-544-2444 or visit  
KOHLERPower.com**

**TP-6879 3/15a**

© 2014, 2015 by Kohler Co. All rights reserved.