

COTEK

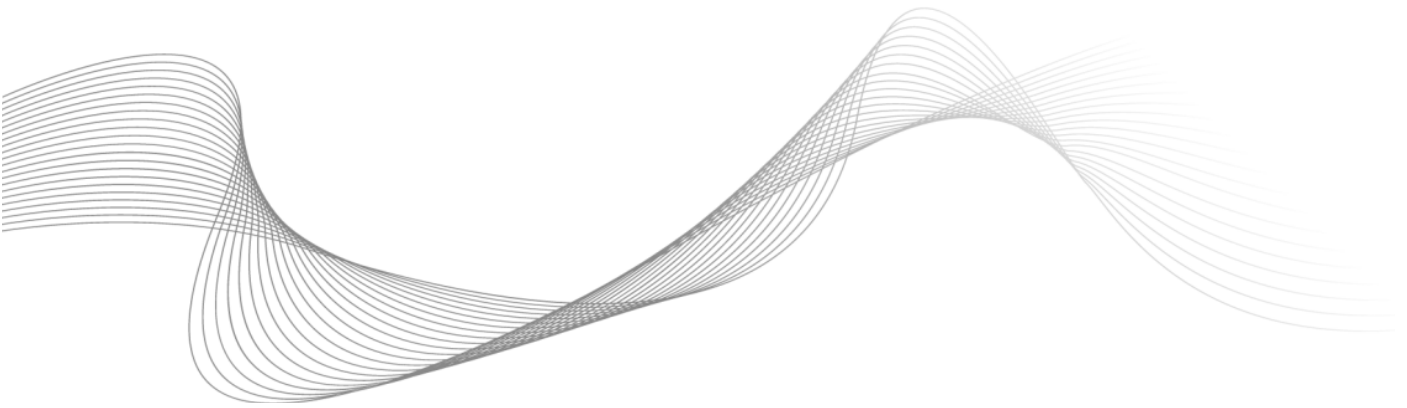

S Series User's Manual

S150/300/500

*PURE SINE WAVE
POWER INVERTER*

Table of Contents

1. Safety Instructions	1
1-1. General Safety Precautions.....	1
1-2. Precautions When Working with Batteries	1
2. Functional Characteristics Introduction	2
2-1. Features.....	2
2-2. Mechanical Drawing	2
2-3. S150 Specification	3
2-4. S300 Specification	4
2-5. S500 Specification	5
3. Instructions.....	6
3-1. Front Panel Introduction	6
3-2. Rear Panel Introduction.....	8
3-3. AC Safety Grounding	9
3-4. Making DC Wiring Connections.....	9
3-5. Installation.....	10
4. Troubleshooting	11
5. Maintenance	12
6. Warranty.....	12

1. Safety Instructions



WARNING!

Before installing and using the inverter, please read the following safety information carefully.

1-1. General Safety Precautions

- 1-1-1. Do not expose the inverter to water, mist, snow, or dust. To reduce the risk of hazard, do not cover or obstruct the ventilation shaft.
To avoid overheating, do not install the inverter in a zero-clearance compartment.
- 1-1-2. To avoid the risk of fire and electronic shock, make sure that existing wiring is in good electrical condition and not undersized. Do not operate the inverter with damaged or substandard wiring.
- 1-1-3. There are some components in the inverter that can cause arcs and sparks.
To prevent from fire or explosion, do not put batteries, flammable materials, or anything that should be ignition-protected around the inverter.

1-2. Precautions When Working with Batteries

- 1-2-1. If battery acid contacts your skin or clothing, you need to wash it out immediately with soap and water. If acid enters into your eyes, immediately flush your eyes with running cold water for at least 20 minutes and get medical attention immediately.
- 1-2-2. Never smoke or make a spark or flame in the vicinity of batteries or engines.
- 1-2-3. Do not drop metal tools on the battery. The resulting spark or short-circuit on the battery or other electrical parts may cause an explosion.
- 1-2-4. Remove personal metal items such as rings, bracelets, necklaces, and watches when working with a lead-acid battery. A lead-acid battery may produce a short-circuit current whose temperature is high enough to weld these metal items and cause a severe burn.

2. Functional Characteristics Introduction

2-1. Features

- Low Frequency transformer design is capable of driving high reactive and capacitive loads
- Power ON / OFF remote control (Green Terminal)
- Input & output fully isolation
- Thermal control fan
- Input protection : Reverse Polarity (Fuse) / Under Voltage / Over Voltage
- Output protection : Short Circuit / Overload / Over Temperature

2-2. Mechanical Drawing

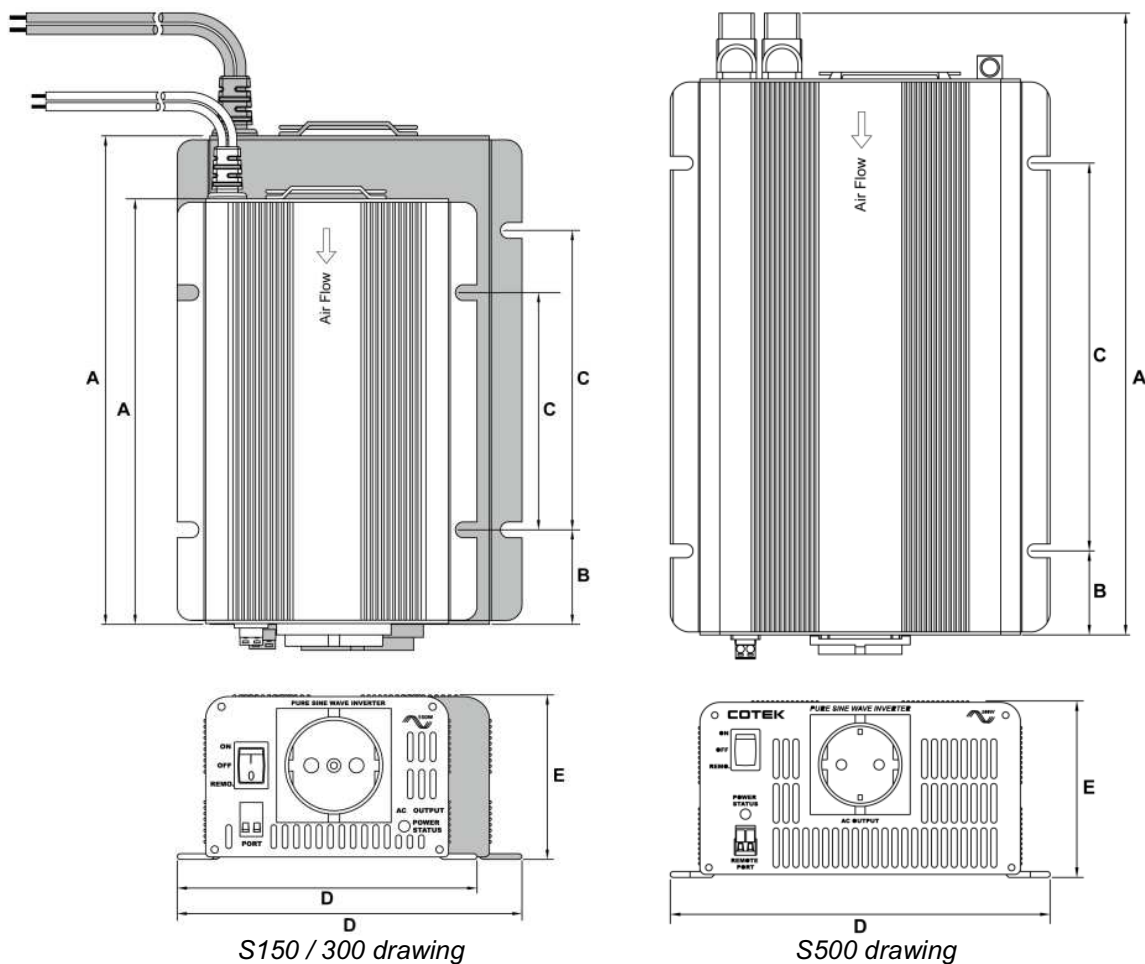

Model	A (mm)	B (mm)	C (mm)	D (mm)	E (mm)
S150	188	41.5	105.0	132	73
S300	215	41.5	132.0	154	73
S500	314	42.5	196.0	192	89

2-3. S150 Specification

Specification Item	Model No.			
	S150-112	S150-124	S150-212	S150-224
AC Voltage	100 / 110 / 120 VAC ± 5%		220 / 230 / 240 VAC ± 3%	
Rated Power	150W			
Surge Power	200W			
Waveform	Pure Sine Wave (THD < 6.0%)			
Frequency	50 / 60Hz ± 0.5%			
Power Factor Allowed	cosθ -90° ~ cosθ +90°			
Standard Receptacles	GFCI / NEMA		Schuko / Australia / UK / Universal / IEC	
No Load Current Draw	0.20A	0.16A	0.22A	0.16A
DC Voltage	12V	24V	12V	24V
Input Voltage Range	10.5~15.0 VDC	21.0~30.0 VDC	10.5~15.0 VDC	21.0~30.0 VDC
Efficiency (Typ.)	87%	88%	87%	88%
Protection	Overload, Short Circuit, Reverse Polarity (Fuse), Over / Under Input Voltage, Over Temperature.			
Remote Control	Yes, On/Off controlled by external switch			
Working Temperature	0 ~ 40 °C			
Storage Temp. & Humidity	-30 ~ 70°C, 10~95% RH			
Safety Standards	Certified UL 458 (Only for "GFCI" receptacles)		Certified EN 60950-1	
Isolation Resistance	I/P – O/P: 100M Ohms / 500VDC			
EMI Conduction & Radiation	Certified FCC class B		Certified EN 55022; EN 61000-3-2, -3-3, -6-3; EN 61204-3	
EMS Immunity	----		Certified EN 61204-3; EN 61000-6-1; EN55024; ENV50204; IEC 61000-4-2, 3, 4, 5, 6, 8, 11	
E-mark	----		Certified CISPR25 ISO 11452-2; ISO 7637-2	
Fan Cooling	Thermostatically controlled			
Dimensions (WxHxD)	132x73x188 mm / 5.20x2.87x7.40 inch			
Weight	2.84kg			

NOTE : The specifications are subject to change without notice.

2-4. S300 Specification

Specification	Model No.			
	S300-112	S300-124	S300-212	S300-224
AC Voltage	100 / 110 / 120 VAC ± 5%		220 / 230 / 240 VAC ± 3%	
Rated Power	300W			
Surge Power	400W			
Waveform	Pure Sine Wave (THD < 6.0%)			
Frequency	50 / 60Hz ± 0.5%			
Power Factor Allowed	cosθ -90° ~ cosθ +90°			
Standard Receptacles	GFCI / NEMA		Schuko / Australia / UK / Universal / IEC	
No Load Current Draw	0.24A	0.28A	0.26A	0.28A
DC Voltage	12V	24V	12V	24V
Input Voltage Range	10.5~15.0 VDC	21.0~30.0 VDC	10.5~15.0 VDC	21.0~30.0 VDC
Efficiency (Typ.)	89%	89%	89%	89%
Protection	Overload, Short Circuit, Reverse Polarity (Fuse), Over / Under Input Voltage, Over Temperature.			
Remote Control	Yes, On/Off controlled by external switch			
Working Temperature	0 ~ 40 °C			
Storage Temp. & Humidity	-30 ~ 70°C, 10~95% RH			
Safety Standards	Certified UL 458 (Only for "GFCI" receptacles)		Certified EN 60950-1	
Isolation Resistance	I/P – O/P: 100M Ohms / 500VDC			
EMI Conduction & Radiation	Certified FCC class B		Certified EN 55022; EN 61000-3-2, -3-3, -6-3; EN 61204-3	
EMS Immunity	----		Certified EN 61204-3; EN 61000-6-1; EN55024; ENV50204; IEC 61000-4-2, 3, 4, 5, 6, 8, 11	
E-mark	----		Certified CISPR25 ISO 11452-2; ISO 7637-2	
Fan Cooling	Thermostatically controlled			
Dimensions (WxHxD)	154x73x215 mm / 6.06x2.87x8.46 inch			
Weight	4.06kg			

NOTE : The specifications are subject to change without notice.

2-5. S500 Specification

Specification	Model No.			
	S500-112	S500-124	S500-212	S500-224
AC Voltage	100/110/115/120 VAC ± 5%		200/220/230/240 VAC ± 3%	
Rated Power	500W			
Surge Power	500W~625W(1min) , 625~750W(10s)			
Waveform	Pure Sine Wave (THD < 3.0%)			
Frequency	50 / 60Hz ± 0.5%			
Power Factor Allowed	cosθ -90° ~ cosθ +90°			
Standard Receptacles	GFCI / NEMA		Schuko / Australia / UK / Universal	
No Load Current Draw	0.5A	0.4A	0.7A	0.4A
DC Voltage	12V	24V	12V	24V
Input Voltage Range	10.5~16.0 VDC	21.0~32.0 VDC	10.5~16.0 VDC	21.0~32.0 VDC
Efficiency (Typ.)	89%	89%	89%	89%
Protection	Overload, Short Circuit, Reverse Polarity (Fuse), Over / Under Input Voltage, Over Temperature.			
Remote Control	Yes, On/Off controlled by external switch			
Working Temperature	-20 ~ 40 °C			
Storage Temp. & Humidity	-30 ~ 70°C, 10~95% RH			
Safety Standards	Certified UL 458 (Only for "GFCI" receptacles)		Certified EN 60950-1	
Isolation Resistance	I/P – O/P: 100M Ohms / 500VDC			
EMI Conduction & Radiation	Certified FCC class B		Certified EN 55022; EN 61000-3-2, -3-3, -6-3; EN 61204-3	
EMS Immunity	----		Certified EN 61204-3; EN 61000-6-1; EN55024; ENV50204; IEC 61000-4-2, 3, 4, 5, 6, 8, 11	
E-Mark	----		Certified CISPR 25 ISO 11452-2; ISO 7637-2	
Fan Cooling	Thermostatically controlled			
Dimensions (WxHxD)	192x90x314 mm / 7.56x3.54x12.36 inch			
Weight	6.00kg			

NOTE : The specifications are subject to change without notice.

3. Instructions

S150, S300 and S500 series are very reliable, portable, and fully protected. These pure sine inverters are used in a wide range of applications such as vehicles, office equipment, home entertainment, electronic appliances, etc.

To have the most effective power inverter performance, it must be installed and used properly. Please read the instructions of this manual before you install and operate this model.

3-1. Front Panel Introduction

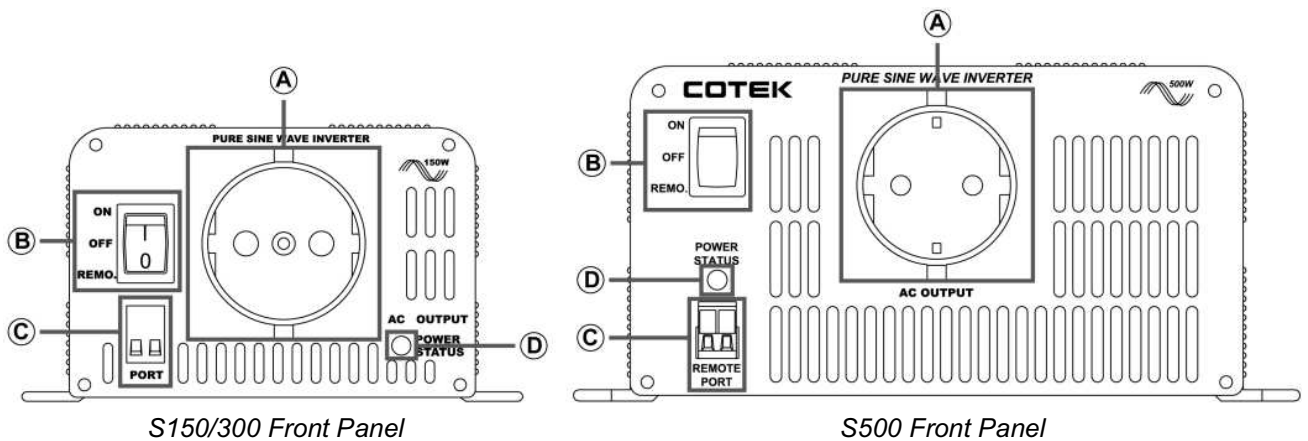

S150/300 Front Panel

S500 Front Panel

Model	S150 / S300 / S500
Ⓐ	AC output socket
Ⓑ	Main switch
Ⓒ	Remote port
Ⓓ	Power status LED

3-1-1. AC output (Outlet Sockets available) Ⓐ :

North America (GFCI)	NEMA 5-20R	United Kingdom	Universal
Continental European	Australia / New Zealand	IEC-1 (Only SK700)	IEC-2 (Only SK700)

3-1-2. Main switch[Ⓑ] and remote port[Ⓒ] :

The 3-stage switch is for turning the unit ON/OFF or putting in to the remote mode.

- 3-1-1-1. Before installing the inverter, make sure the main switch is set to "OFF ".
- 3-1-1-2. Before using the remote unit, make sure the main switch is set to "REMOTE ".
- 3-1-1-3. Ensure the remote control contact is off.
- 3-1-1-4. Remote Port : Place 0.75mm² and Screw type cable between the remote port and the panel.
- 3-1-1-5. To turn ON / OFF inverter via remote switch.

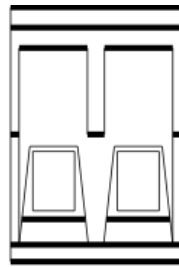

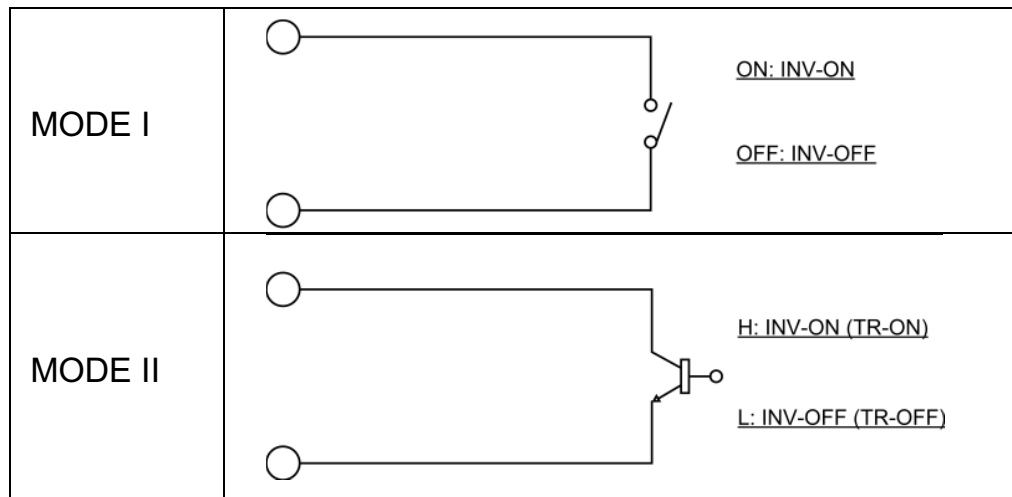

REMOTE PORT

REMOTE PORT



3-1-3. Power Status LED [Ⓓ] :

LED Status		Description
Solid Green		AC Power OK
Fast Red Blink		OVP

LED Status		Description
Slow Red Blink		UVP
Intermittently Red Blink		OTP
Solid Red		OLP

3-2. Rear Panel Introduction

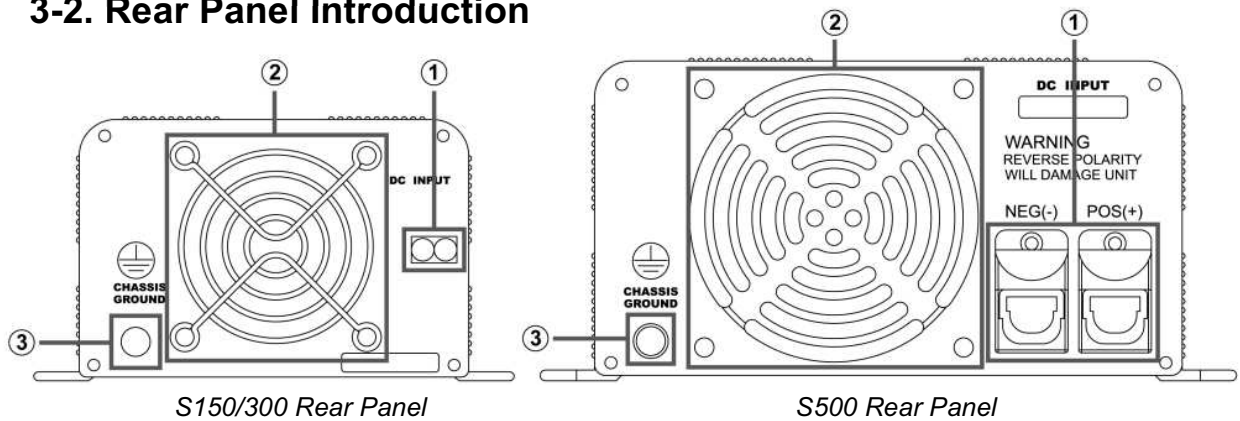

Model	S150 / S300 / S500
①	DC input terminal
②	Ventilation mesh
③	Chassis ground

3-2-1. Input terminals :

Connect the input terminal to 12v / 24V battery or other 12V / 24V power source. 【 + 】represents positive, and【 - 】represents negative. Reverse polarity connection will blow the internal fuse and may damage inverter permanently.

3-2-2. Ventilation mesh :

Maintain at least a 3-inch distance from anything surrounding it.

3-2-3. Use wire # 8 AWG to connect Chassis ground with Vehicle Chassis.



WARNING!

Do not combine the 12V model with 24V battery or the unit will be destroyed immediately.

Operating with the inverter without a proper ground connection may cause an electrical safety hazard.

Damage caused by reversed polarity is not covered by the warranty. Ensure the power switch is in the OFF position before putting the battery in.

3-3. AC Safety Grounding

Neutral Grounding (GFCI'S) :

110V models : The neutral conductor of the AC output circuit of the Inverter is automatically connected to the safety ground during inverter operation. This conforms to National Electrical Code requirements that separately derived from AC sources (such as inverters and generators) which have their neutral conductors tied to ground in the same way as the neutral conductors from the utility tied to ground at the AC breaker panel. For models configured with a transfer relay, while AC utility power is present and the Inverter is in bypass mode, this connection (the neutral of the Inverter's AC output to input safety ground) is not present so that the utility neutral is only connected to ground at your breaker panel, as required. COTEK has tested the following GFCI-properly when connected to the output of the Inverter.



WARNING!

Never connect the inverter's output to the AC distribution grid, such as the household AC wall outlet.

It will damage the Inverter.

220V models : There is no connection made inside the inverter from either the line or neutral conductor to safety ground.

3-4. Making DC Wiring Connections

The DC cables should be as short as possible (less than 6 feet / 1.8 meters ideally)

The size of the cable should be thick enough to limit the voltage drop to less than 2% when carrying the maximum input current to prevent frequent low-input voltage warnings, and shutdown.

The following sizes of cables and fuses are recommended for up to 6 ft. distance between the batteries and the inverter.



WARNING!

The fuse must be installed on positive cable.

Failure to place a fuse on "+" cables running between the inverter and battery may cause damage to the inverter and will void warranty.

Increasing S500 DC cable size helps improve the situation. COTEK recommends the following cables for optimum inverter performance. (Apply both 110V and 220V versions)

Model	Wire AWG	Inline fuse
S500-112	# 8	≥ 125A
S500-124	# 10	≥ 80A
S500-212	# 8	≥ 125A
S500-224	# 10	≥ 80A

NOTE : Batteries are capable of providing very large currents in case of short circuit. The fuse should be as close to the positive battery terminal as possible. Use Bussmann ANN series fuses (will also require Fuse Block 4164) or equivalent.

3-5. Installation

Before connecting your applications to the inverter, always check the power draw of your appliances. The inverter can supply surge power for a short time so as to start up electrical equipment such as motors and pumps which need more power while starting up.



When all the above requirements are satisfied and all connections are made, it's time to turn on the inverter by switching the power to ' I ' position. The sine wave filters provide sine wave output voltage when driven from the AC outlet.

To save the battery power, you are highly recommended to turn off the inverter when it is not being used.

DC input voltage status as follows :

Model	DC Input Over Voltage		DC Input Under Voltage	
	Shut-down	Restart	Shut-down	Restart
S150/S300 12V models	15.3VDC	14.8VDC	10.5VDC	12.5VDC
S150/S300 24V models	30.6VDC	29.6VDC	21.0VDC	25.0VDC
S500 12V models	16.0VDC	14.5VDC	10.5VDC	12.5VDC
S500 24V models	32.0VDC	29.0VDC	21.0VDC	25.0VDC

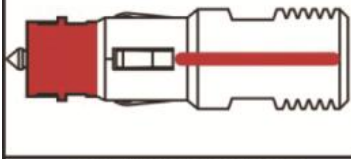
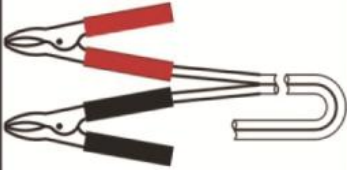
3-6. DC Input (Outlet sockets available)

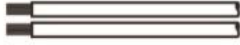
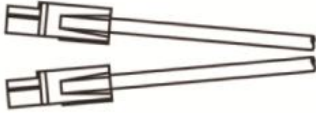
CIGARETTE	CLAMP	POWER CLAW
		
STRIPPED WIRE	PP45	
		

4. Troubleshooting

	<p>WARNING!</p> <p>Do not open or disassemble the inverter. Attempting to service the unit yourself may cause the risk of electrical shock or fire.</p>
--	--

Problems and Symptoms	Possible Cause	Solutions
No output voltage, the LED glows Red.		
a. Power status light is blinking red fast.	Over input voltage.	Check input voltage. Discharge the battery.
b. Power status light is blinking red slowly.	Low input voltage.	Charge the battery. Check connections and cable.
c. Power status light is blinking red intermittently.	Thermal shutdown	Improve ventilation. Make sure ventilation openings in the inverter are not obstructed. Lower ambient temperature.
d. Power status light is blinking red steadily.	Short circuit, Wiring error, Overload	Check AC wiring for short circuit. Remove load.

5. Maintenance

Very little maintenance is required to keep your inverter operating properly. You should clean the exterior of the unit periodically with a damp cloth to prevent accumulation of dust and dirt. At the same time, tighten the screws on the DC input terminals.

6. Warranty

We guarantee this product against defects in materials and workmanship for a period of 24 months from the date of purchase and will repair or replace any defective power inverters if you directly return them to us with postage paid.

This warranty will be considered void if the unit has been misused, altered, or accidentally damaged. COTEK is not liable for anything that occurs as a result of the user's fault.

COTEK

No.33, Sec. 2, Renhe Rd., Daxi Dist., Taoyuan City 33548, Taiwan

Phone : +886-3-3891999 FAX : +886-3-3802333

[http : // www.cotek.com.tw](http://www.cotek.com.tw)

2015.01._A1