

## General Installation Manual Photovoltaic Module HIT®

### VBHNxxxKA01 series

#### Model No.

- VBHN320KA01
- VBHN315KA01
- VBHN310KA01

Thank you for choosing Panasonic HIT®. Please read this manual completely before installation or use of Panasonic PV(photovoltaic) modules. With proper operation and maintenance, Panasonic HIT® will provide you with clean, renewable solar electricity for many years. This manual contains important installation, maintenance and safety information. The word "module" as used in this manual refers to one or more PV modules. Retain this manual for future reference. The module is considered to be in compliance with UL 1703 only when the module is mounted in the manner specified by the mounting instructions below.

SANYO is part of the Panasonic Group and is in charge of the manufacturing process for Panasonic HIT®.

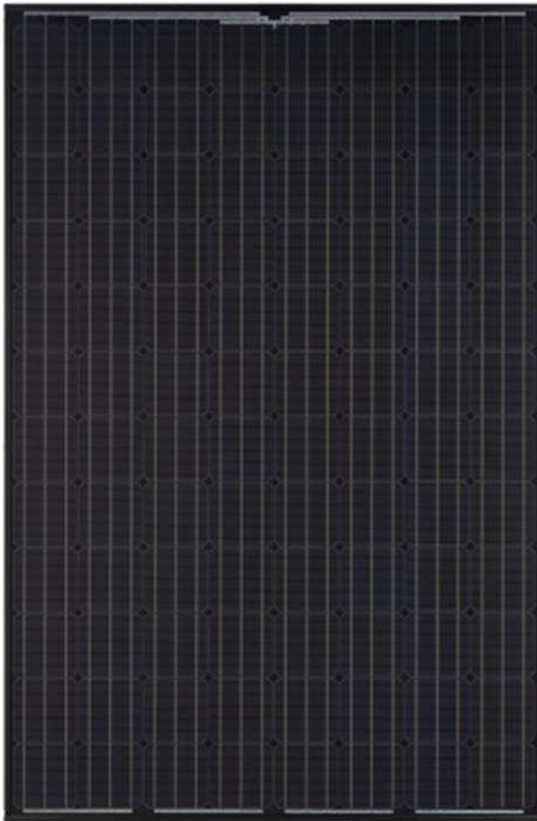

VBHNxxxKA01 series

## Contents

Please read before installation

### Safety Precautions

- General Information :3
- Warning :3
- Cautions :3
- General Safety :3
- UL Listing Information :3

### Installation

- General :3
- Notes on Installation :3
- Operating Conditions :4
- Special Conditions :5

### Specifications

- Note on Specifications :5
- Mechanical Loading :5

### Unpacking and handling :5

### Wiring

- General :5
- Module Wiring :5
- Array Wiring :5
- Earth Ground Wiring :5
- Grounding Locations :6
- Grounding Methods :6
- Module Terminations :7
- Junction Box and Terminals :7
- Conduit :7

### Diodes :7

### Maintenance :7

### Disclaimer of Liability :7

### Contact Information :7

---

"HIT" is a registered trademark of Panasonic Group.

Other product and service names listed in this manual are trademarks or registered trademarks of their respective companies.

---



## Safety Precautions

### General Information

The installation of solar modules requires a great degree of skill and should only be performed by qualified licensed professionals, including, without limitation, licensed contractors and electricians.



### WARNING

- All instructions should be read and understood before attempting to install, wire, operate, and maintain a photovoltaic module.
- Contact with electrically active parts of the module such as terminals can result in burns, sparks, and lethal shock whether the module is connected or disconnected.
- The installer assumes the risk of all injury that might occur during installation, including, without limitation, the risk of electric shock.
- The modules generate DC (direct current) electrical energy when exposed to sunlight or other light sources. Even a single module produces enough voltage and current, to cause shocks and burns if safety precautions are not followed.
- The shock hazard increases as modules are connected in parallel, producing higher current, and as modules are connected in series, producing higher voltages.
- Do not hit the back sheet of a module by the connector or other things.
- To avoid the hazard of electric sparks, shock, fire, burns, damage and injury:
- Work only in dry conditions, with dry modules and dry tools.
- In order to avoid submerging cables and connectors in the water, cables must be fixed either to the module frame using cable fixing holes or to the mounting structure.
- Do not stand or step on modules. Do not puncture, cut, scratch or damage the backsheet of a module. Backsheet damage will void a module's Limited Warranty and may cause fire. Never use modules with a damaged back sheet.
- Do not allow children and unauthorized persons near the installation or storage site of modules.
- Completely ground all modules.
- Do not disassemble a module, attempt any repair, open the junction box cover, nor remove any parts installed by Panasonic. There are no user serviceable parts within the module or junction box.
- Unauthorized persons - except the qualified licensed professional - should not perform any electrical work, including wiring,
- Wear suitable clothing, guards, eye protection and gloves to prevent you from direct contact with 30 VDC or greater.

- Wear non-slip gloves and carry modules by the frame using both hands. Do not attempt to carry a module by yourself.
- Do not carry a module by its wires or junction box.
- Do not drop anything on the surface of a module.
- Ensure all system components are compatible, and they do not subject the module to mechanical or electrical hazards.
- Sparks may occur; do not install modules where flammable gases or vapors are present.
- Never rest or leave a module unsupported or unsecured.
- Do not drop modules.
- Do not use or install broken modules.
- Do not artificially concentrate sunlight on a module.
- Do not touch the junction box terminals.
- Do not change the wiring of bypass diodes.
- Do not touch a module unnecessarily. The glass surface and frames get hot. There is a risk of burn.



### CAUTIONS

- Use a module for its intended purpose only.
- Do not treat the back sheet, frame, or front surface with paint or adhesives, to avoid reducing its' functionality, damage, and causing inoperable conditions, and other unknown troubles.
- Do not insert PV cable between back side and mounting structure rail.

### GENERAL SAFETY

- Follow all permissions, installation and inspection requirements.
- Before installing modules, contact the appropriate authorities having jurisdiction to determine permissions, installation and inspection requirements, which should be followed.
- Electrically ground modules for all systems of any voltage. If not otherwise specified, it is recommended that requirements of the latest National Electrical Code (USA) or Canadian Electric Code (Canada) or other national or international electrical standards be followed. Refer to "Earth Ground Wiring" section for more information.
- Be sure that the building or structure (roof, façade, etc.) where the modules are being installed has enough strength to support the load of the modules.
- For modules mounted on roofs, special structures may be required to help provide proper installation support.
- The fire rating of this module is valid only when mounted in the manner specified in the mechanical mounting instructions.
- Both, roof construction and module installation design have an effect on the

fire resistance of a building. Improper installation may contribute to fire hazards.

- The models in this instructions are suitable to maintain the System Fire Class Rating A when used with a Listed mounting system and a roof covering that have been rated as a Class A System when installed on a steep slope roof and/or a low slope roof with "Type 2" modules.
- Additional devices such as ground fault, fuses, and disconnects may be required.
- Do not use modules of different specifications in the same system.
- Follow all safety precautions of other system components which are used.

### UL Listing Information

To satisfy UL requirements, when installing the modules, be sure to:

- 1) Use only stranded or solid copper single-conductor sunlight-resistant cable rated for outdoor use (e.g. type UF or USE) , for all wiring that is exposed to weather.
- 2) Observe the requirements described in sections labeled INSTALLATION and SPECIFICATIONS.

## INSTALLATION

### General

Please read this guide completely before installing or using your Panasonic PV modules. This section contains important electrical and mechanical specifications.

- Modules should be firmly fixed in place in a manner suitable to withstand all expected loads, including wind and snow loads.
- Metals used in locations that are exposed to moisture shall not be employed alone or in combinations that could result in deterioration or corrosion.
- Install modules where they are not shaded by obstacles like buildings and trees. Pay special attention to avoid partially shading the modules by objects during the daytime.
- If needed, contact an Authorized Representative with questions regarding mounting profiles for Panasonic HIT®.

### Notes on Installation

- Clearance between the roof surface and module frame is required to allow cooling air to circulate around the back of the module. This also allows any condensation or moisture to dissipate. The required clearance between the roof surface and the module is more than 4 inch.
- Panasonic recommends the installation method and mounting profile shown in Figure 1-1 and Figure 1-2.
- Figure 1-1 shows that a module should be attached on a mount or support structure rail by corrosive-resistant metal clamps.

- The clamps should be made of aluminum alloy or other material that will reasonably protect against a risk of electrolytic corrosion.
  - Figure 1-2 shows using a bolt and nut for mounting.
  - Recommendation of bolt torque: 10 ft-lbs.
  - The module was tested using Unirac or IronRidge clamps with the specifications see figure 1-1 and below;
- 1) Unirac clamps:
    - Provider: Unirac, Inc.
    - Product Line: SolarMount
    - Clamps type: Top Mounting Clamps (Mid clamp and End clamp)
    - Unirac Part No. 302022C, 302022D, 302027C, 302027D
    - Width: Mid clamp; 1.5"(38 mm), End clamp; 1.9"(48 mm)
    - Thickness: Mid clamp; Nominal thickness 0.075"(1.9mm), End clamp; Nominal thickness 0.125"(3.17mm)
    - Torque: 13.6 N.m(10 ft-lbs).
    - Material: Mid clamp; 300 Stainless steel, End clamp; 6000 Aluminum alloys
    - Note: Please refer to Unirac manual, for installation method.
  - 2) IronRidge clamps:
    - Provider: IronRidge Inc.
    - Product Line: RoofMount
    - Clamps type: Top Mounting Clamps (Grounding mid clamp and End clamp)
    - IronRidge Part No. RS-GD-MCL-225, RS-GD-MCL-225B, 29-7000-224, 29-7000-224B
    - Width: Grounding mid clamp; 1.16"(29.5 mm), End clamp; 1.5"(38 mm)
    - Thickness: Grounding mid clamp; Nominal thickness 0.11"(2.85mm), End clamp; Nominal thickness 0.125"(3.17mm)
    - Torque: 9.5 N.m (85 in-lbs).
    - Material: Grounding mid clamp; 304 Stainless steel, End clamp; 5000 & 6000 Aluminum alloys
    - Note: Please refer to IronRidge manual, for installation method.
- Panasonic does not provide a warranty for clamps. The module warranty Panasonic provides shall be voided if clamps selected by the customer are of an improper material or size

**Operating Conditions**

Panasonic requires that modules be operated within the following Operating Conditions:

- 1) Terrestrial applications only-no outer space or Special Conditions (see below).
- 2) The operating temperature must be within -40°C (-40 °F) to 85°C (185 °F).
- 3) The wind pressure load of the installation site should be less than 2,400N/m<sup>2</sup> (50PSF)

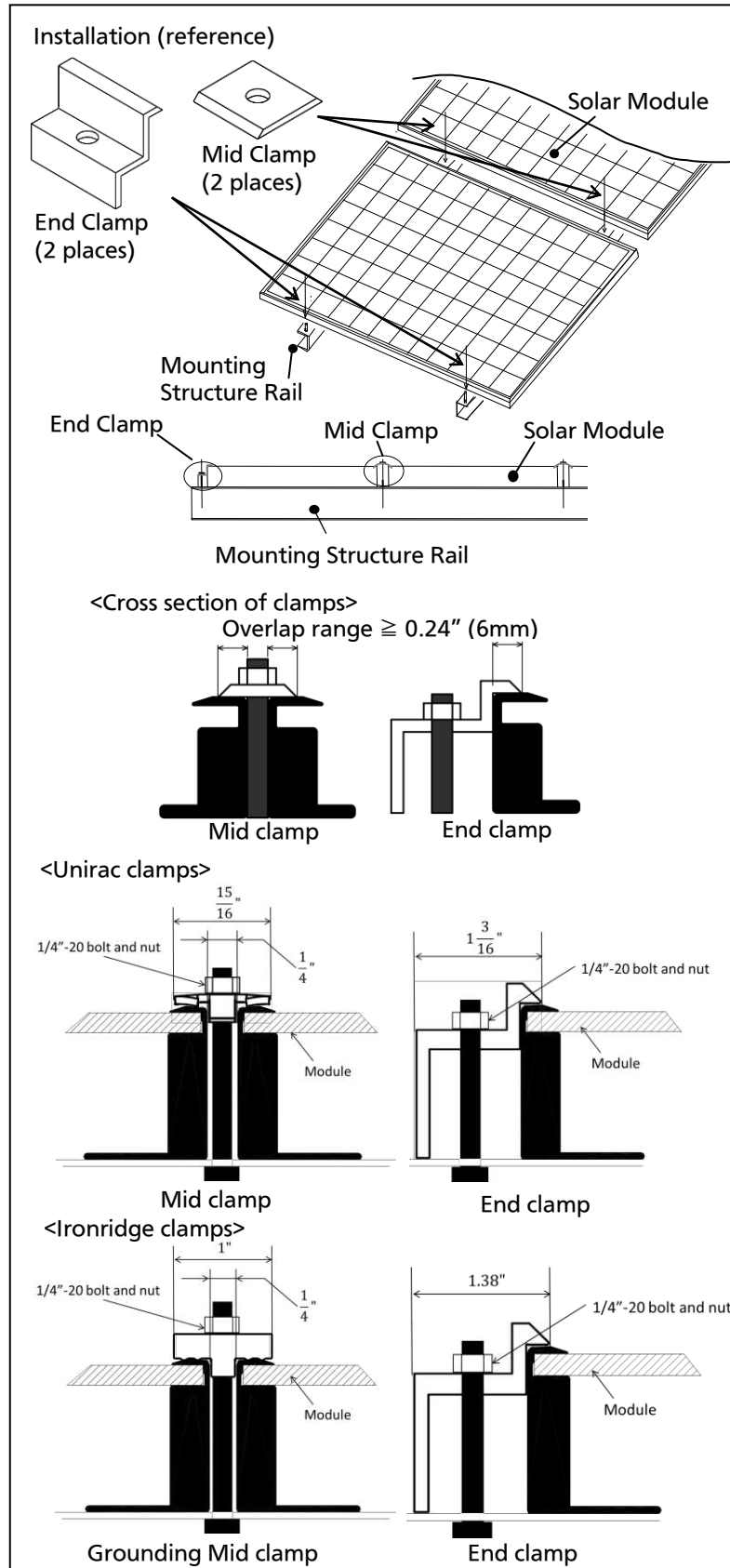

Figure 1-1. Installation

- 4) Some environmental conditions could apply. Please refer to Panasonic's warranty exclusions.

#### Special Conditions

- 1) The operating temperature and installation place are different from the recommended Operating Conditions.
- 2) Salt damage is severe at the installation place.
- 3) Hail and snow damage is excessive at the installation place.
- 4) Sand and dust damage is excessive at the installation place.
- 5) Air pollution, chemically active vapors, acid rain, and/or soot, etc. are excessive at the installation place.

## SPECIFICATIONS

#### Notes on Specifications

- 1) Rated electrical characteristics are within -5% to +10% of the values measured at Standard Test Conditions (STC). STC conditions are; Irradiance of 1000W/m<sup>2</sup>, 25°C cell temperature, and solar spectral irradiance per IEC 60904-3. Note: At the time of shipment, Panasonic guarantees the output level of its modules to be -0/+10% against Rated Power in SPECIFICATIONS based on factory inspection at STC conditions.
- 2) Under real conditions, a photovoltaic module may experience conditions that produce more current and/or voltage than reported at Standard Test Conditions. Therefore, the I<sub>sc</sub> value of modules should be multiplied by a factor of 1.25 to determine ampacity. An additional factor of 1.25 may be required for sizing conductors, fuses, disconnects, etc. Please refer to section 690.8 of the National Electric Code (NEC) for guidelines. The V<sub>oc</sub> must be factored according to the lowest recorded operating temperature recorded for the location where the modules will be installed. Please refer to section 690.7 of the NEC for more information regarding voltage temperature factors.
- 3) The current output for the modules shown in the SPECIFICATIONS section is measured at Standard Test Conditions. These conditions may not be frequently observed in actual practice.

#### Mechanical Loading

- The modules should be mounted at the four (4) quarter points by the means shown in Figure 2.
- This method offers a maximum load of 2,400 N/m<sup>2</sup> (50PSF) in a static state on the module surface.
- Note: This mechanical loading value was tested using the mounting device specified in section "Notes on Installation".

## UNPACKING AND HANDLING

- Do not hit the back sheet of a module by the connector when unpacking and handling.
- To avoid the damage of the back sheet by connector, fix the cables to the frame with tape after unpacking. (see below)
- After fixing the cable to the frame, do not stack modules to avoid the damage of the cable.
- Do not handle modules by their cables or junction box. Handle them by the frame with both hands in any situation.

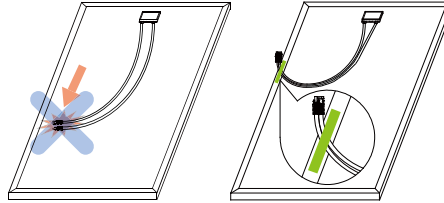

## WIRING

#### General

- All wiring should be done in accordance with applicable electrical codes.
- Wiring methods should be in accordance with the NEC in USA or CEC in Canada.
- A qualified, licensed professional should do all wiring.
- Wiring should be protected to help ensure personal safety and to prevent damage.
- All modules connected in series should be of the same model number and/or type.
- Do not connect modules in parallel without using connection devices that connect to appropriate FUSE for each series string or each module.
- Do not disconnect terminals while modules generate electricity and connect electrical load to avoid the hazard of electrical shock.
- To avoid the hazard of electric shock and sparks, please connect each cable after confirming the polarity of them is correct.
- Cable conduits should be used in locations where the wiring is inaccessible to children or small animals.

#### Module Wiring

- The number of modules that can be wired in series is recommended to be seven (7) or fewer. If connecting eight (8) modules in series, check local temperature conditions and follow the National Electric Code (690.7) to ensure compliance with maximum voltage limitations.
- Modules are not designed for "off-grid" or battery charging systems, because of their operating voltage. Therefore, it is not recommended to use them for charging batteries.
- These modules contain factory installed bypass diodes. If these modules are incorrectly connected to each other, the

bypass diodes, cable, or junction box may be damaged.

- The PV module comes pre-wired. Each module has two #12 AWG type PV-wire stranded sunlight resistant output cables each terminated with connectors. The positive (+) terminal has a male connector while the negative (-) terminal has a female connector. The module wiring is solely for series connections only, i.e. male (+) to female (-) interconnections. When making field wiring connections to the pre-attached connectors use only approved connectors from Table.1.

#### Array Wiring

- The term "array" is used to describe the assembly of several modules on a support structure with associated wiring.
- Use copper wire which insulation is sunlight resistant and can withstand the maximum possible system open circuit voltage.
- Interconnection of modules must be performed in a professional fashion. Wires should be secured and only reasonable slack should be allowed.
- Check local codes for requirements.

#### Earth Ground Wiring

- A module with exposed conductive parts is considered to be in compliance with UL 1703 only when it is electrically grounded in accordance with the instructions presented below and the requirements of the National Electrical Code.
- All modules should be grounded. All structures or metallic components in direct contact with the modules or electric wires should be properly grounded too. To avoid the hazards of electric shock or fire, modules should be grounded by the frame only at the locations marked in this manual (see grounding methods below).
- The array frame shall be grounded in accordance with NEC Article 250 (USA) or the CEC in Canada.
- Bonding shall be by a positive means, such as clamping, riveting, bolted or screwed connectors, or welding, soldering or brazing. If the bonding means depends upon screw threads two or more screws or two full threads of a single screw must engage the metal
- Great care should be exercised to ensure that corrosion caused by the grounding means be avoided.
- Corrosion can increase the resistance of the grounding connection on the module, or can even cause the grounding connection to fail entirely. Corrosion can be caused by the effects of weather, humidity, dirt and so on. It can also be caused when two dissimilar metals are in contact (galvanic reaction).
- The module frame material is aluminum/magnesium alloy.

- All fasteners (nuts, bolts, washers, screws, etc.) must be stainless steel unless otherwise specified.
- Length of bolt should not be more than 0.78" (20 mm) in order to avoid contacting the back-sheet of the module.
- Acceptable grounding wire is following. IlSCO Corp. GBL-4DBT 10-14AWG-Solid, 4-6, 8, 10-14AWG-Strand  
Burndy L L C CL501TN 14AWG-Solid, 14-4AWG-Strand  
Tyco Electronics Corp. 1954381-1/1954381-2 10-12AWG Solid
- Each ledge on the module frame has two larger holes for bolts (0.205" diameter (5.2 mm)). These ground holes are marked with a "G" or "ground mark" adjacent to their location on the frame rail (see Figure 3.1).
- Ground wires must be connected to the module's metal frame at one of these locations.
- Lay-in lugs or grounding clips can be used to ground Panasonic PV modules. Both methods are explained below, please choose one.

**Grounding Locations (or grounding holes)**

- Using bolt and nut** (see Figures 3.3 and 3.5)
- If using this method, use one of the larger holes with diameter of 0.205" (5.2 mm)
    - The bolt and nut size should be No.8 (0.164" diameter (4.16 mm)), or No.10 (0.190" diameter (4.83 mm)) or M5 (0.197" diameter (5.0 mm)).
    - Star washers must be used to make contact through the anodization of the module frame.
  - In this case, the screw threads are not providing the electrical ground contact.
  - Recommended torque value in tightening bolt and nut is 2.3 N.m (20in-lb).

**Grounding Methods**

- Where common grounding hardware (nuts, bolts, star washers, spilt-ring lock washers, flat washers and the like) is used to attach a listed grounding/bonding device, the attachment must be made in conformance with the grounding device manufacturer's instructions.
- Common hardware items such as nuts, bolts, star washers, lock washers and the like have not been evaluated for electrical conductivity or for use as grounding devices and should be used only for maintaining mechanical connections and holding electrical grounding devices in the proper position for electrical conductivity. Such devices, where supplied with the module and evaluated through the requirements in UL 1703, may be used for grounding connections in accordance with the instructions provided with the module.

**Wire connection using cup washers** (see Figures 3.2)

- The use of cup washers is to prevent wire from slipping out from under the screw head (and/or the flat washer).
- Make sure that the cup washer is placed between the wire and the module frame.
- Choose an adequate size for the cup washer and the flat washer so that the wire is fully clamped between them.
- Note: Cup washers are also called terminal cup washers.
- The cup washers should be stainless steel, or a cup washer made of brass may be used only if a large flat washer made of stainless steel is inserted between the module frame and the cup washer.
- Choose the adequate size for the large flat washer (between the module frame and the cup washer) so that the cup washer doesn't contact the module frame and is fixed stably to the module frame.

**Method- Use a bolt and nut (see Figures 3.1 and 3.2)**

- If using this method, use one of the larger holes with diameter of 0.205" (5.2 mm)
- The bolt and nut size should be No.8 (0.164" diameter (4.16 mm)), or No.10 (0.190" diameter (4.83 mm)) or M5 (0.197" diameter (5.0 mm)).
- Star washers must be used to make contact through the anodization of the module for this method.
- In this case, the screw threads are not providing the electrical ground contact.

**Using a lay-in lug with bolt and nut**

- If using this method, please follow instructions in previous section regarding using bolts and nuts with larger

grounding holes.

- Use a grounding tin plated solid copper lay-in lug rated for direct burial and outdoor use. Lug must be used ILSCO GBL-4DBT, BurndyCL501TN.
- Attach grounding lug to module frame using a stainless steel bolt and lock-nut as shown in Figure 3.3.
- Tighten stainless steel set screw at the torque specified by lug manufacturer to secure copper wire.
- The specified torque is following
  - IlSCO Corp. GBL-4DBT 10-14AWG-Solid -> 20 in-lbs, 4-6AWG-Strand -> 35 in-lbs, 8AWG-Strand -> 25 in-lbs, 10-14AWG-Strand -> 20 in-lbs
  - Burndy L L C CL501TN 14AWG-Solid -> 35 in-lbs, 14AWG-Strand -> 35 in-lbs, 4AWG-Strand -> 45 in-lbs
- Recommended torque value in tightening bolt and nut is 2.3 N.m (20in-lb).

**Using a Grounding Clip with bolt and nut**

- Use Tyco Electronics 1954381-2 as grounding clip.
- As shown in Figure 3.4, place the grounding clip onto the module frame.
- Thread the hex nut onto the end of the screw, then using a 3/8-in. wrench, tighten the nut. Recommended torque value in tightening bolt and nut is between 1.7 and 2.2 Nm.
- Insert the wire into the wire slot. Press down on both ends of the wire.
- Manually, or using channel lock pliers, push the slider over the base until it covers the base. This will terminate the

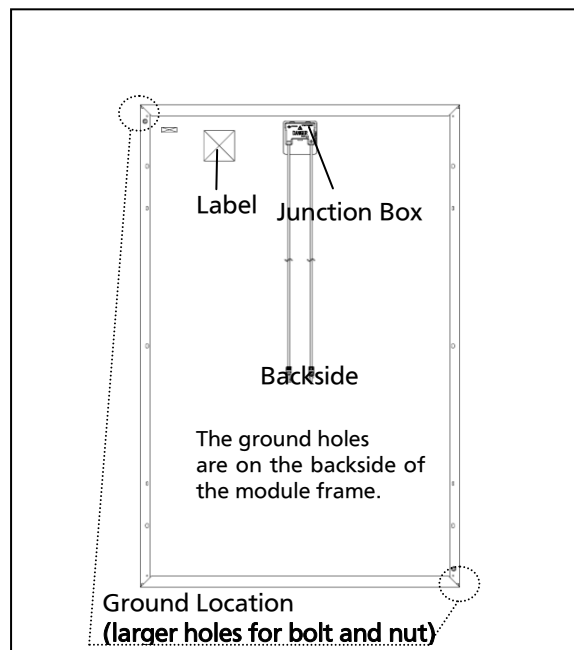

**Figure 3.1  
Module Ground Position**



wire.

- For more information, please refer to Instruction sheet issued by Tyco Electronics.

**Module Terminations**

- A junction box as a terminal enclosure is equipped for electrical connections. VBHNxxxKA01 Modules are equipped with MC™ plugs as a terminal enclosure. Use these MC™ plugs for electrical connections (see Figure 4.1).
- Connectors between modules must be inserted until they click.

**Junction Box and Terminals**

- Modules are equipped with one junction box containing terminals for both, positive and negative polarity, and bypass diodes.
- Each terminal is dedicated to one polarity with the polarity symbols engraved onto the body of the junction box (see Figure 4.2).
- Each terminal is provided with factory installed lead cables and a latching connector for series and string connections. Always use these connectors and do not detach them from cables.
- Latching connectors are type IV and made by Multi-Contact. Supplied connectors listed by UL.
- In order to comply with NEC 2008, a locking sleeve needs to be used with all connectors that are exposed.
- The locking sleeve (PV-SSH4) is made by Multi-Contact and can only be released with a special tool also made by Multi-contact (PV-MS). Locking sleeves are not supplied with modules and must be purchased separately.

**Conduit**

- In applications where wire raceways or conduit are used, follow the applicable codes for outdoor installations..
- Verify that all fittings are properly installed to protect wires against damage and prevent moisture intrusion.

**DIODES**

**Bypass Diodes**

- When modules in series strings are partially shaded, it may cause reverse voltage across cells or modules, because the current from other cells in the same series is forced to flow through the shaded area. This may cause undesirable heating to occur.
- The use of a diode to bypass the shaded area can minimize both heating and array current reduction.
- Modules are equipped with factory installed bypass diodes. The factory-installed diodes provide proper circuit protection for the systems within the specified system voltage, so that you do not need any other additional bypass diodes.

**MAINTENANCE**

- Some maintenance is recommended to maintain optimal output performance of the solar modules.
- It is also recommended to inspect the electrical and mechanical connections annually.
- If you need electrical or mechanical inspection or maintenance, it is recommended to have a licensed authorized professional carry out the inspection or maintenance to avoid the hazards of electric shock or injury.
- The return of any modules will not be accepted by Panasonic unless prior written authorization has been given by Panasonic.
- As part of our policy of continuous improvement Panasonic reserves the right to change product specifications at any time without prior notice.

**Disclaimer of Liability**

- Panasonic does not assume responsibility and expressly disclaims liability for loss, damage, or expense arising out of, or in

any way connected with installation, operation, use, or maintenance by using this manual.

- Panasonic assumes no responsibility for any infringement of patents or other rights of third parties, which may result from use of modules.
- No license is granted by implication or under any patent or patent rights. The information in this manual is believed to be reliable, but does not constitute an expressed and/or implied warranty.
- The return of any modules will not be accepted by Panasonic unless prior written authorization has been given by Panasonic.
- As part of Panasonic’s policy of continuous improvement, Panasonic reserves the right to change product specifications at any time without prior notice.

**Contact Information**

Panasonic Eco Solutions of North America  
Two Riverfront Plaza. 5th Floor, Newark, NJ 07102  
[panasonicHIT@us.panasonic.com](mailto:panasonicHIT@us.panasonic.com)  
[business.panasonic.com/solarpanels](http://business.panasonic.com/solarpanels)

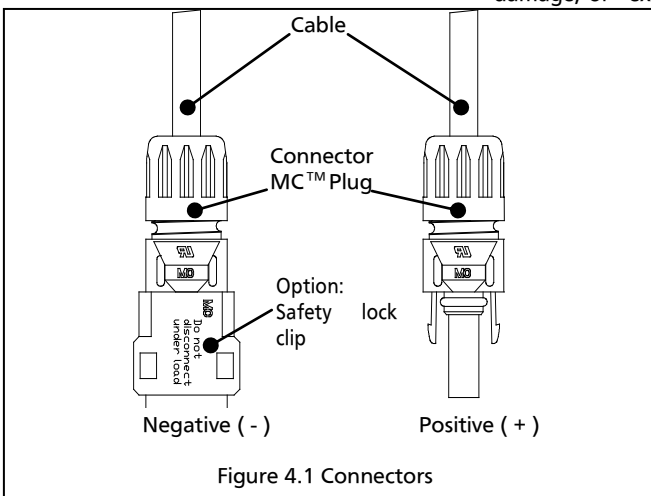

Figure 4.1 Connectors

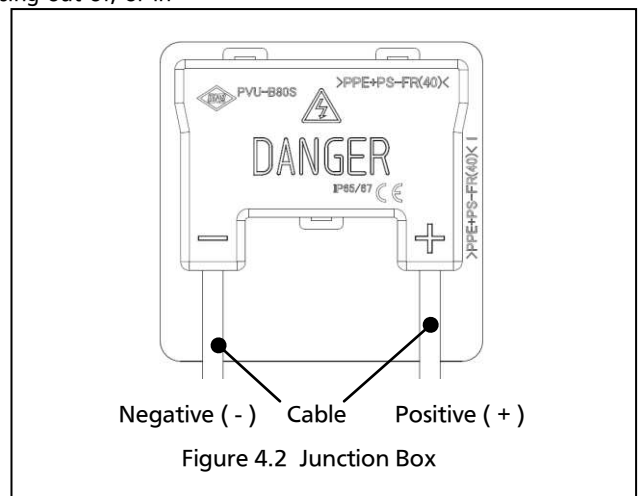
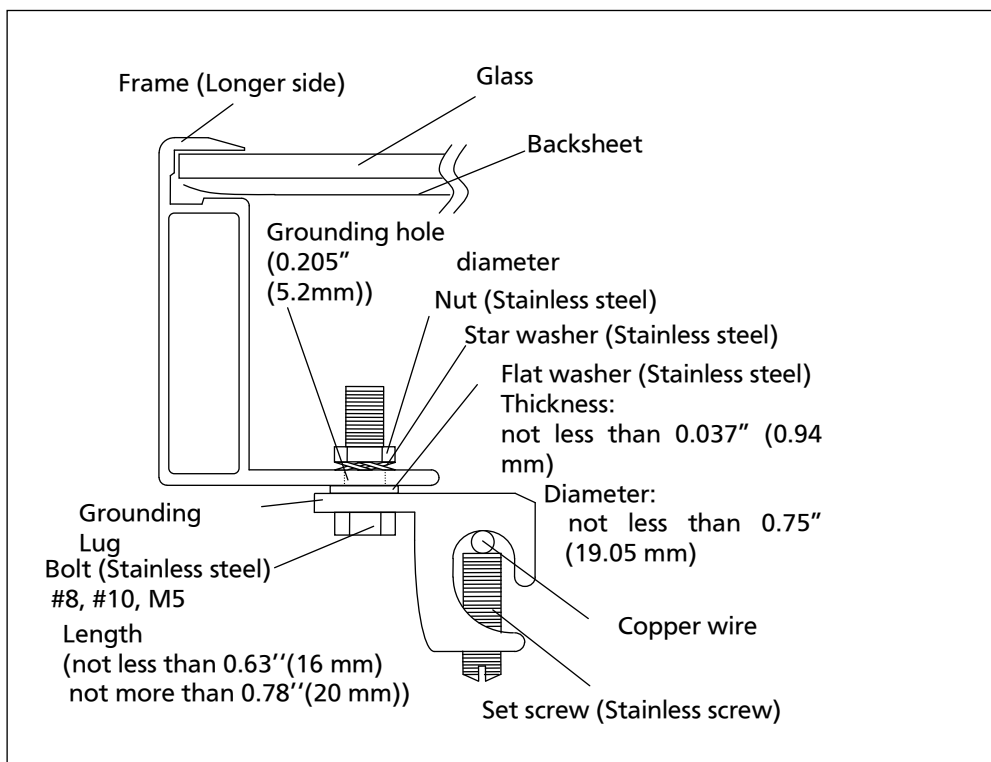
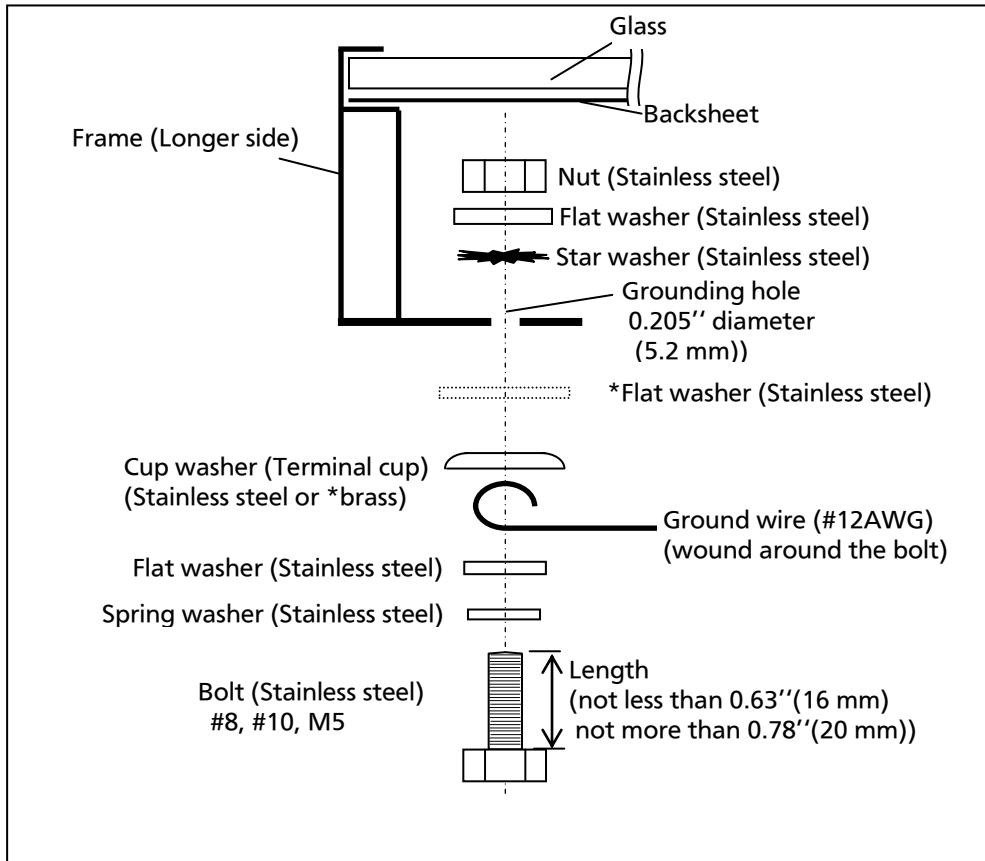

Figure 4.2 Junction Box

Table.1 Approved connectors list

Manufacturer	Model #	Contact Information
<p>Multi-Contact AG</p> <p>Multi-Contact Essen GmbH</p>	<p>PV-KST4, PV-KBT4 followed by /2.5 or /6, followed by "I" or "II", followed by -UR. or - may be followed by additional suffixes, may be followed by suffix numbers and letters.</p> <p>PV-PLS-S, PV-PLS-B, may be followed by suffix numbers and letters, may be followed by suffix numbers and letters.</p> <p>Male PV connectors,            PV-KST4-EVO2/2.5, 6 or 10, followed by I, II, III or IV, followed by -UR.            Female PV connectors,            PV-KBT4-EVO2/2.5, 6 or 10, followed by I, II, III or IV, followed by -UR</p> <p>PV-AZS4 (male), PV-AZB4 (female)</p>	<p><a href="http://www.multi-contact.com">http://www.multi-contact.com</a></p>





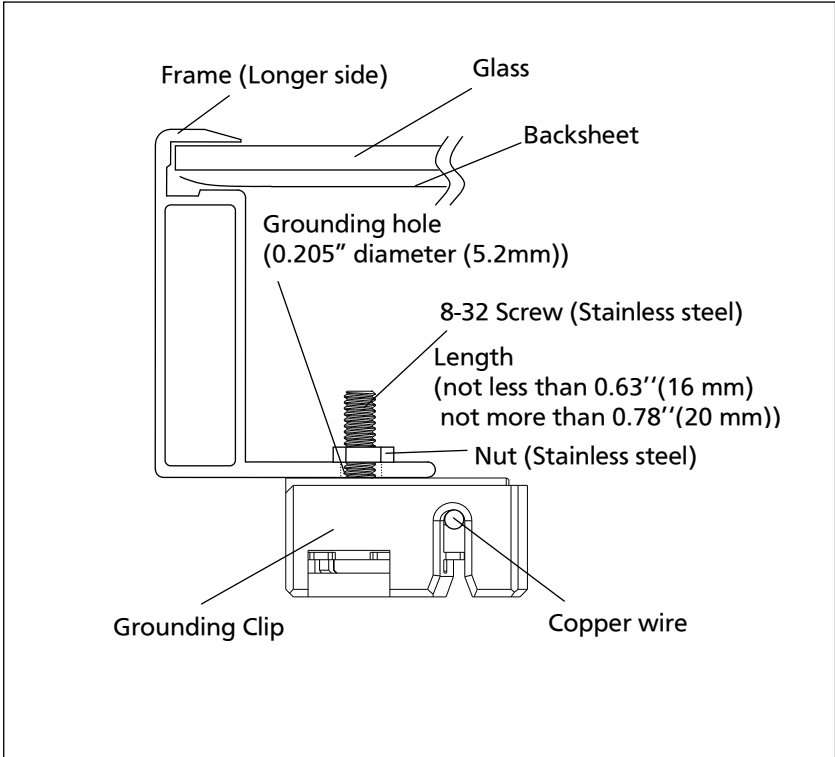
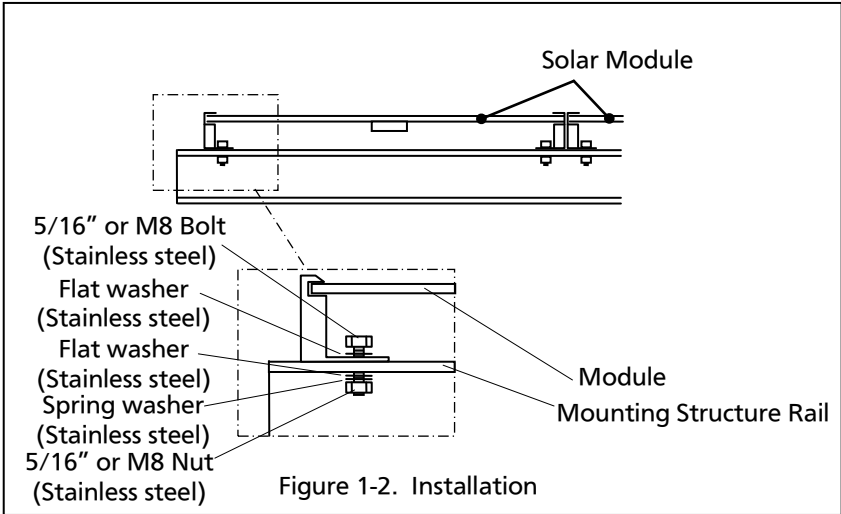

Figure 3.4  
 Grounding method  
 Using Grounding Clip with bolt  
 and nut

Note: Use the ground holes  
 illustrated in Figure 3.1.  
 Grounding Clip Assemblies: Tyco  
 Electronics 1954381-2



# SPECIFICATIONS

## Electrical Specifications

Model	VBHN320KA01	VBHN315KA01	VBHN310KA01
Cell Number in Series	96	96	96
Rated Power, Watts (Pmax)	320	315	310
Maximum Power Voltage (Vpm)	58.7	58.4	58.1
Maximum Power Current (Ipm)	5.46	5.40	5.34
Open Circuit Voltage (Voc)	70.5	70.2	69.9
Short Circuit Current (Isc)	5.89	5.83	5.78
Cell Type	Silicon hetero-junction*	Silicon hetero-junction*	Silicon hetero-junction*
Maximum System Voltage	600	600	600
Factory Installed Bypass Diodes	4	4	4
Maximum series fuse (A)	15	15	15

Silicon hetero-junction\*: Monocrystalline silicon/amorphous silicon hetero-junction

## Mechanical Specifications

Length, mm (inches)	1590 (62.60)
Width, mm (inches)	1053 (41.46)
Frame Depth, mm (inches)	35 (1.38)
Weight, kg (pounds)	19 (41.89)

